

Environmental Product Declaration



In accordance with ISO 14025 and EN 15804:2012+A2:2019 for:

CENTRALTUBI GAS DE20 SDR11 S5
CENTRALTUBI GAS DE32 SDR11 S5
CENTRALTUBI GAS DE50 SDR11 S5
CENTRALTUBI GAS DE75 SDR11 S5
CENTRALTUBI GAS DE110 SDR11 S5

CENTRALTUBI GAS DE140 SDR11 S5
CENTRALTUBI GAS DE160 SDR11 S5
CENTRALTUBI GAS DE200 SDR11 S5
CENTRALTUBI GAS DE280 SDR11 S5
CENTRALTUBI GAS DE355 SDR11 S5

from

Centraltubi S.p.A.

plant:

Via Foglia 11, 61026 Lunano (PU)



Program operator:	EPDItaly, www.epditaly.it
Publisher:	EPDItaly
Declaration number:	CTU_02_2024
Registration number:	EPDITALY0694
Issue date:	2024-06-28
Valid until:	2029-06-28

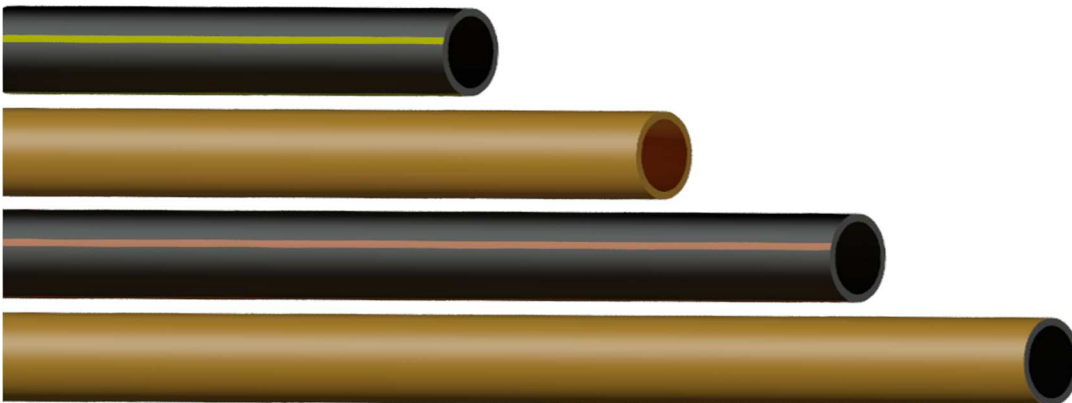

1. General information

EPD owner	<p>Centraltubi S.p.A.</p> <p>Via Foglia 11, 61026 Lunano (PU), Italia</p> <p>www.tubi.net/aziende/centraltubi/</p>
Plant involved in the declaration	<p>Centraltubi S.p.A.</p> <p>Via Foglia 11, 61026 Lunano (PU), Italy</p>
Scope of application	<p>This Environmental Product Declaration (EPD) is valid for CENTRALTUBI pipes. The production facility is in Lunano (PU). The type of declaration is related to the declared pipe produced in Lunano. The life cycle assessment is representative for the product introduced in the declaration for the given system boundaries.</p>
Program operator	<p>EPDItaly</p> <p>Via Gaetano De Castillia 10, 20124 Milano, Italy.</p> <p>www.epditaly.it</p>
Independent check	<p>This declaration has been developed referring to EPDItaly, following the General Program Instruction; further information and the document itself are available at: www.epditaly.it. EPD document valid within the following geographical area: Italy.</p> <p>CEN standard EN 15804 served as the core PCR (PCR ICMQ-001/15 rev.3).</p> <p>Independent verification of the declaration and data, according to EN ISO 14025:2010.</p>
UN CPC Code	3632 - Tubes, pipes and hoses, and fittings therefor, of plastics
Corporate contact	Alberto Mezzanotti; a.mezzanotti@tubi.net
Technical support	TETIS Institute srl (www.tetisinstitute.it)
Comparability	<p>Environmental statements published within the same product category, but from different programs, may not be comparable. In particular, EPDs of construction products may not be comparable if they do not comply with EN 15804+A2.</p>
Accountability	<p>Centraltubi S.p.A. relieves EPDItaly from any non-compliance with environmental legislation. The holder of the declaration will be responsible for the information and supporting evidence; EPDItaly</p>

	declines all responsibility for the manufacturer's information, data and results of the life cycle assessment.
Reference document	This declaration has been developed following the General Programme Instruction document of EPDItaly, available at www.epditaly.it .
Product Category Rules (PCR)	PCR ICMQ-001/15 rev.3 EN 15804+A2:2019 is the framework reference for PCRs.
Products names:	CENTRALTUBI GAS DE20 SDR11 S5 CENTRALTUBI GAS DE32 SDR11 S5 CENTRALTUBI GAS DE50 SDR11 S5 CENTRALTUBI GAS DE75 SDR11 S5 CENTRALTUBI GAS DE110 SDR11 S5 CENTRALTUBI GAS DE140 SDR11 S5 CENTRALTUBI GAS DE160 SDR11 S5 CENTRALTUBI GAS DE200 SDR11 S5 CENTRALTUBI GAS DE280 SDR11 S5 CENTRALTUBI GAS DE355 SDR11 S5
Products identification:	<i>Pipes made from polyethylene PE100 or PE100-RC for piping systems in the field of the supply of gaseous fuels, according with EN 1555-2.</i>
Products description	<i>Plastic pipe for the supply of gaseous fuels made of polyethylene compound classified PE100 and PE100-RC with orange and black colour, minimum required strength (MRS) 10 MPa, maximum operating pressure 10 bar at a reference temperature of 20°C. Produced, tested and third part certified according with (UNI) EN 1555-2.</i>

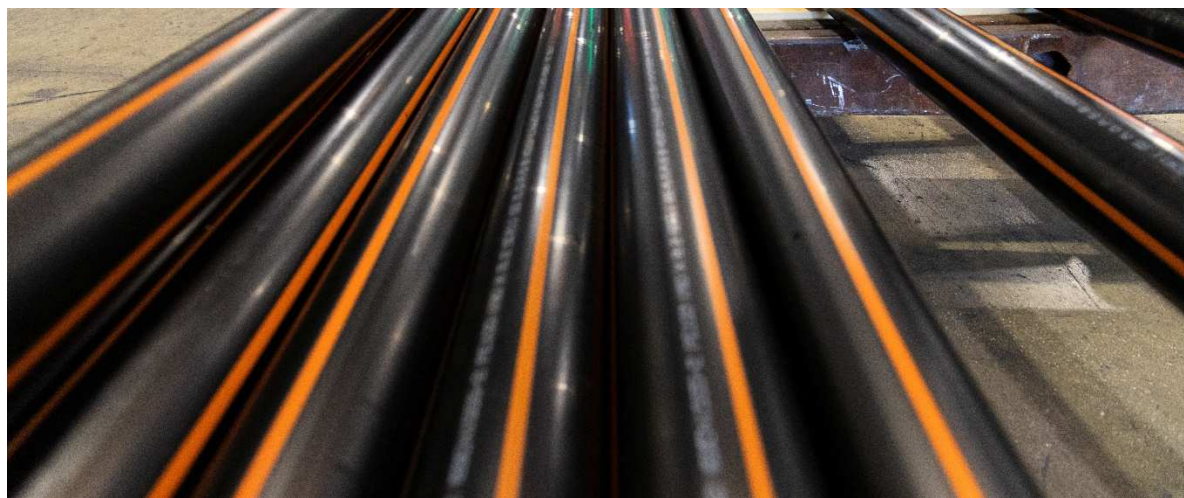

The EPD owner has the sole ownership, liability, and responsibility for the EPD.

CEN standard EN 15804 serves as the core PCR ^a
Independent verification of the declaration and data, according to EN ISO 14025:2010 <input type="checkbox"/> internal <input checked="" type="checkbox"/> external
Third party verifier: ICMQ SpA, via De Castillia, 10 20124 Milano (www.icmq.it).
^a Product Category Rules.

EPDs within the same product category but registered in different EPD programmes, or not compliant with EN 15804, may not be comparable. For two EPDs to be comparable, they must be based on the same PCR (including the same version number) or be based on fully-aligned PCRs or versions of PCRs; cover products with identical functions, technical performances and use (e.g. identical declared/functional units); have equivalent system boundaries and descriptions of data; apply equivalent data quality requirements, methods of data collection, and allocation methods; apply identical cut-off rules and impact assessment methods (including the same version of characterisation factors); have equivalent content declarations; and be valid at the time of comparison. For further information about comparability, see EN 15804 and ISO 14025.



2. Company description

Centraltubi S.p.A. was founded in 1979. It is the founder Company of what later became System Group: a group of 20 companies belonging to the holding “HB Boscarini S.p.A.”. Centraltubi S.p.A. produces smooth solid wall polyethylene (PE) pipes, in high and medium density for water supply, gas distribution, drainage and sewerage, irrigation, slotted pipes for underground drainage, dredging, protection of electrical and telecommunications cables. The company is equipped with high-tech extrusion lines, which allow it to obtain notable levels of productivity and high process quality standards. Centraltubi S.p.A. carries out all the processes for the production of products internally without outsourcing specific activities or processes, and targets many foreign markets, in addition to the Italian national one. The production range goes from the (external) diameter 7 mm to 1000 mm, divided into numerous pressure and annular stiffness classes based on the thicknesses and characteristics of the basic raw material.



Centraltubi S.p.A. is a company operating with QUALITY MANAGEMENT systems in accordance with the UNI EN ISO 9001 standard, ENVIRONMENTAL QUALITY MANAGEMENT systems in accordance with the UNI EN ISO 14001 standard and SAFETY MANAGEMENT systems in accordance with the UNI ISO 45001 standard, all regularly certified by accredited third parties. Centraltubi S.p.A. it is also regularly registered with the PolieCo Consortium (National Consortium for the recycling of polyethylene-based waste goods), mandatory by law (Legislative Decree 152/2006 – art. 234). The quality of the products is ensured by a careful selection of materials and a scrupulous control plan, as well as by the numerous inspection visits carried out by the various certification institutes issuing the quality marks, for the different nations and on various standards based on target applications. The most important quality marks are:

- IIP UNI (Italian Plastics Institute)
- Piip/a, Piip/b and Piip/c
- IMQ (Quality Mark Institute)
- BV (Bureau Veritas)
- DVGW (Deutscher Verein des Gas und Wasserfaches)
- DIN plus (issued by the German regulatory institute DIN CERTCO, certification institute of the TÜV Rheinland Gruppe and DIN)

- SVGW (Schweizerischer Verein des Gas und Wasserfaches)
- Nordic Poly Mark (for countries in the Scandinavian area)
- FM Approvals

In addition to the product certifications, there are also those relating to suitability for contact with water intended for human consumption, such as:

- Certificate of conformity with the provisions of Ministerial Decree 6 April 2004 n. 174 (Italy) from accredited third party laboratory tests (CHELAB S.r.l.)
- WRAS (potability in UK)
- DK VAND (potability in Denmark, accepted in all Scandinavian countries).

Together with other System Group companies, Centraltubi S.p.A. annually draws up a Sustainability Report according to the GRI standards in force. The conformity of the document and the correctness of the reported data are certified by IIP (Italian Institute of Plastics).

CISQ is a member of

THE INTERNATIONAL CERTIFICATION NETWORK
www.iqnet-certification.com

IONet, the association of the world's first class certification bodies, is the largest provider of management System Certification in the world. IONet is composed of more than 29 bodies and counts over 120 subsidiaries all over the globe.

CERTIFICATO I
CERTIFICATE N.

n° 2052 / 2022 — Rev. 1

Si certifica che il Sistema d
We hereby certify that the Environment

CENTRALTUBI
sede legale: VIA FOGLIA, 11
UNITA' OPERATIVE /
VIA FOGLIA, 11 — 61026 LUNANO (PU)
VIA CIRCONVALLAZIONE S...

Prodotti
Products

Sistemi di tubazioni di materia plastica per la distribuzione di gas combustibili - Polietilene (PE) - Tubi
Plastics piping systems for supply of gaseous fuels - Polyethylene (PE) - Part 2 - Pipes

Gamma di prodotti
Range of products

vedere allegato / see annex

Norma
Standard

UNI EN 1555 -2 : 2021

Nome commerciale

CENTRALTUBI GAS

è conforme alla norma
is in compliance with the standard

UNI EN ISO 14001:2015

UNI EN ISO 9001:2015

SVGW
Schweizerischer Verein des
Gas- und Wasserfaches
Grütlistrasse 44
CH-8027 Zürich

Zertifizierungsstelle Gas
Schweizerischer Verein des
Gas- und Wasserfaches
Eschenstrasse 10
CH-8603 Scherzenbach

LABORATOIRE
NATIONAL
DE METROLOGIE
ET D'ESSAIS

Organisme de certification
mandaté pour la marque NF
par AFNOR Certification

CERTIFICAT
NF 114 Tubes PE pour réseaux
de gaz et d'eau
NF 114 PE pipes
for gas and water networks
Délivré à / granted to
CENTRALTUBI S.p.A
Via Foglia 11
ITALY 61026 LUNANO (PU)
Pour les produits suivants / For the following products
TUBES EN POLYETHYLENE POUR DISTRIBUTION DE GAZ COMBUSTIBLES (Gr1)
Polyethylene pipes for gaseous fuel distribution (Gr1)

ZERTIFIKAT Nr. 10-033-9 SVGW

Antragsteller: Frigerio System Group, CH-6600 Locarno
Hersteller: Centraltubi S.p.A., IT-61026 Lunano
Vertreter / Vertreiber: Frigerio System Group, CH-6600 Locarno
Gestützt auf das Prüf- und Zertifizierungsreglement der SVGW Prüf- und Zertifizierungsstelle Gas sowie auf den
Remarks to the type PAS 1075 Type 1 - G
Basis EN 1555-2
Testing basis PAS 1075:2009-04
Certification Scheme Plastic Piping Systems (Pressure Pipes and Fittings) (2017-05)
Mark of conformity

3. Goal and scope of the EPD

The full products' life cycle is considered (type of EPD: cradle to grave), and the following modules are defined in this EPD:

- Module **A1** includes all the processes related the extraction of raw materials for the production of pipes (virgin HDPE and carbon black), for the production of the pipes' packaging and the energy supply from different sources (electricity, natural gas and diesel);
- Module **A2** considers the transport to the factory gate of the plant;
- Module **A3** considers all the processes related to pipes' manufacturing as well as waste transport and treatment, direct emissions into air and water;
- Module **A4** is related to the transport from the production site to the construction site;
- Module **A5** includes all the processes related to the pipes' installation activities like energy consumption, yard waste processing, excavated soil management, production and transport to the site of cover materials (bitumen, concrete, sand, gravel), production and transport of ancillary elements to the building site;
- Module **B1** considers the use of the installed product. During the use of plastic piping systems, a zero-impact scenario is considered;
- Module **B2** includes the maintenance of the product. A zero-impact scenario is considered;
- Modules **B3-B4-B5** are related to the repair, replacement and refurbishment of the products. If the products are properly installed no repair, replacement or refurbishment processes are necessary. A zero-impact scenario is considered;
- Modules **B6-B7** consider energy use and operational water to operate building integrated technical systems. No operational energy or water use are considered. A zero-impact scenario is considered;
- Module **C1** considers deconstruction, including dismantling or demolition of the product from the building site. Since these products are not for provisional but for definitive use, it has been assumed that they will be replaced and not simply removed: as a result, the effect of this intervention will be attributed to the newly constructed pipes that will be installed. The impact of such action is previously considered in module A5 of this study. A zero-impact scenario is considered;
- Module **C2** considers transportation of the substituted pipes to a recycling or disposal treatment;
- Module **C3** considers waste processing for products recycling and waste to energy treatment;
- Module **C4** includes all waste disposal and incineration processes, including pre-treatment and management of the disposal site;
- Module **D** includes benefits from all net flows in the end-of-life stage that leave the product boundary system after having passed the end-of-waste stage. Benefits from pipes' recycling are declared within this module.

According to the PCR ICMQ-001/15 rev.3 the LCA study and the relative EPD, is "Cradle to grave and module D (A, B, C and D)". Modules included are A1, A2, A3, A4, A5, B, C and D and refers to the products declared in chapter 1.

The production plant is in Lunano (PU). The market range is Italy.

Product stage			Construction process stage		Use stage							End of life stage				Resource recovery stage
Raw material supply	Transport	Manufacturing	Transport	Construction installation	Use	Maintenance	Repair	Replacement	Refurbishment	Operational energy use	Operational water use	De-construction demolition	Transport	Waste processing	Disposal	Reuse-Recovery-Recycling-potential
A1	A2	A3	A4	A5	B1	B2	B3	B4	B5	B6	B7	C1	C2	C3	C4	D
✓	✓	✓	✓	✓	✓	✓	✓	✓	✓	✓	✓	✓	✓	✓	✓	✓

✓ stands for “module included in the study”.

Therefore, the boundaries of the system are illustrated in the following figures.

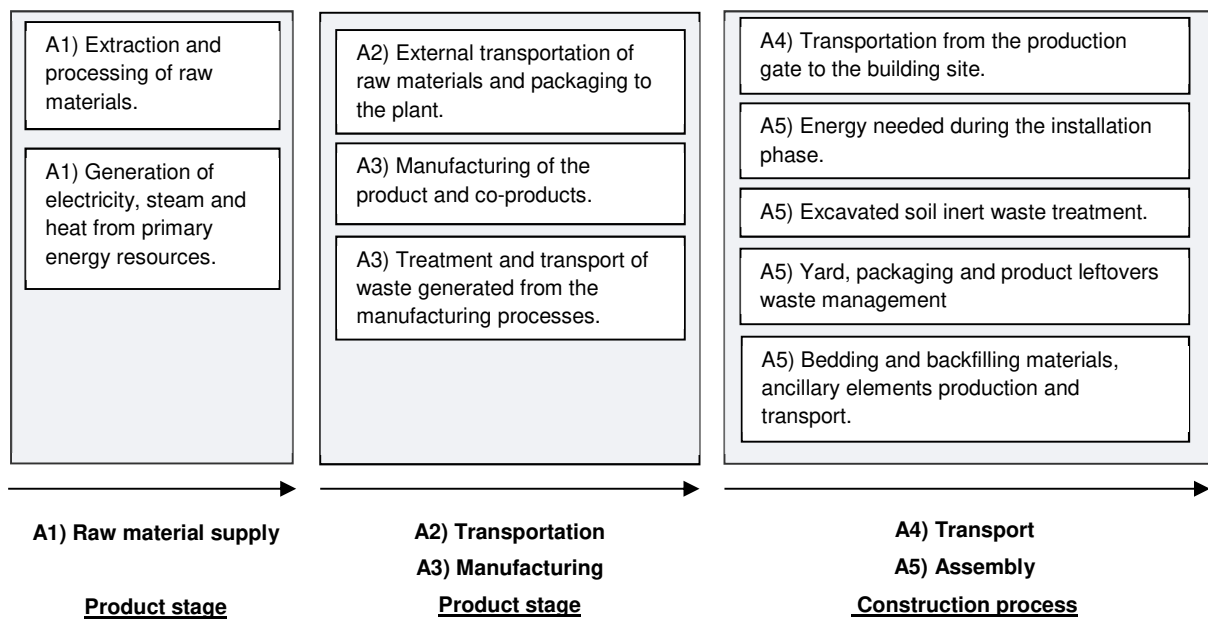

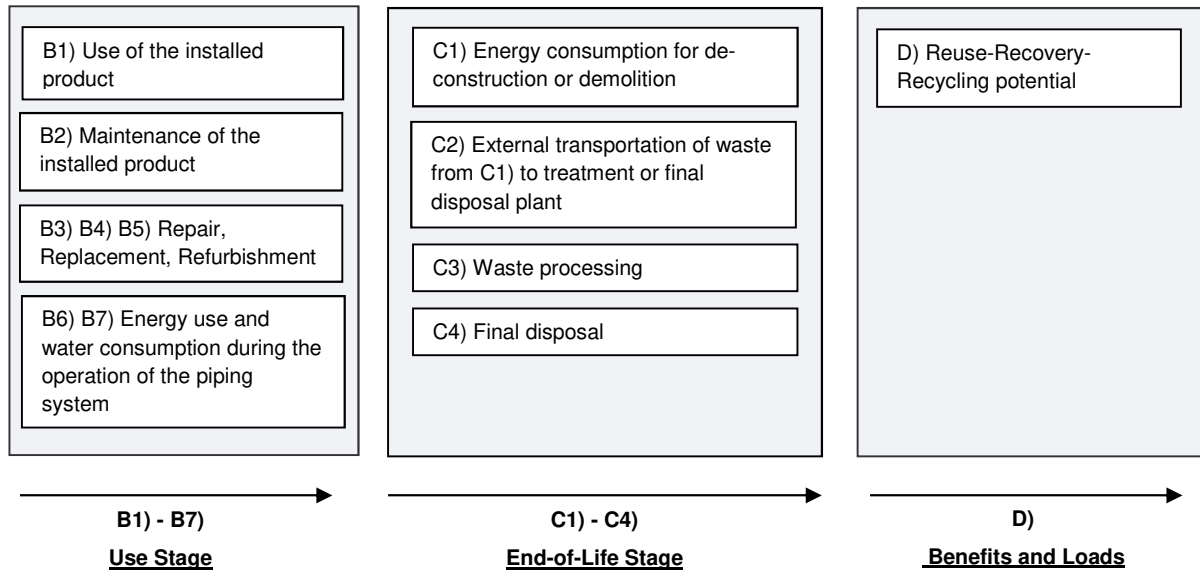

All data refer to the 2022 production and sales.

The declaration is a Type 3 EPD (Product EPD based on a qualified LCA-Tool) according to the EPDIItaly regulation.

Geographical validity:	Italy
Database:	Ecoinvent 3.9
Software:	“Gas, water and cables pipes LCA tool”, implemented through SimaPro 9.5 calculation software. The identification code of the EPD process tool used is: Gas, water and cables pipes LCA tool v.3.0 of 22/01/2024 developed by TETIS Institute srl.
EPD realized by means of a validated algorithm:	In 2023 Centraletubi S.p.A. implemented and certified a Process for EPD generation by using an algorithm that has been validated and certified by ICMQ S.p.A., in agreement with EPDIItaly’s requirements. The process is based on an automatic data collection from the production plant that have been integrated, verified and validated in compliance with internal procedures. The validated algorithm allows the automatic calculation of the indicators reported into the current EPD coming from an LCA model implemented into the EPD process tool.

4. Products description

CENTRALTUBI GAS DE20 SDR11 S5

Minimum and maximum values referring to the pipes characteristics refers to the values given by the reference standard and relies on the data variability. Different ID represents the same pipe with different colouring: differed colour tubes are produced in the same way; the difference in colour defines their different function (gas pipe, water pipe, etc.) and is used solely for distinguishing them logistically; they do not affect the products' environmental performance.

Property	Value			Notes
Product ID	GHUI002000S5 GHNFO02000S5 GEDI002000S5 GMDP002000S5			PE100 Black with yellow external stripes PE100 Black with orange external stripes PE100 RC Black with orange external stripes PE100 RC Black with orange external layer
Pipe material	HDPE – PE100 – PE100-RC			
Content of recycled material	0%			
Number of layers	Solid wall Single or double layer of the same polymer			
Reference service life (RSL)	100 years			According to FprEN 16903 and (Ulrich Schulte and Joachim Hessel, 2006)
Mass conversion factor	0.16 kg/m			
	Min	Max	Average	
Density [kg/m ³]	956	962	959	
Weight [kg/m]	0.15	0.17	0.16	
External diameter [mm]	20	20.3	20.15	
Thickness [mm]	3.0	3.4	3.2	

Property	Value	Test method
Minimum Required Strength (MRS)	10 MPa	EN ISO 9080
Compound density	≥ 930 kg/m ³	EN ISO 1183
Oxidation induction time (OIT)	≥ 20 min	EN ISO 11357-6
Colour	Black with external orange layer or external orange/yellow stripes	
Melt mass flow rate (MFR)	0,2 ≤ MFR ≤ 1,4	EN ISO 1133-1
Water Content	≤ 300 mg/kg	EN ISO 15512
Carbon Black content	2 to 2,5 % by mass	ISO 6964
Carbon Black or pigment dispersion	Grade ≤ 3	ISO 18553
Minimum operating temperature	- 20°C	UNI EN 1555-2
Maximum operating temperature	40°C	UNI EN 1555-2
Hydrostatic Strenght (80°C; 165 h)	5,4 MPa	EN ISO 1167
Elongation at break	≥ 350 %	EN ISO 6259
Longitudinal Reversion	≤ 3 %	EN ISO 2505
Minimum Tensile Strain at yield	19 MPa	EN ISO 6259
Flexural modulus	> 900 MPa	EN ISO 178
Coefficient of Thermal Linear Expansion	0,22 mm/m/°C	

CENTRALTUBI GAS DE32 SDR11 S5

Minimum and maximum values referring to the pipes characteristics refers to the values given by the reference standard and relies on the data variability. Different ID represents the same pipe with different colouring: differed colour tubes are produced in the same way; the difference in colour defines their different function (gas pipe, water pipe, etc.) and is used solely for distinguishing them logistically; they do not affect the products' environmental performance.

Property	Value			Notes
Product ID	GHUI003200S5 GHNFF003200S5 GEDI003200S5 GMDP003200S5			PE100 Black with yellow external stripes PE100 Black with orange external stripes PE100 RC Black with orange external stripes PE100 RC Black with orange external layer
Pipe material	HDPE – PE100 – PE100-RC			
Content of recycled material	0%			
Number of layers	Solid wall Single or double layer of the same polymer			
Reference service life (RSL)	100 years			According to FprEN 16903 and (Ulrich Schulte and Joachim Hessel, 2006)
Mass conversion factor	0.28 kg/m			
	Min	Max	Average	
Density [kg/m ³]	956	962	959	
Weight [kg/m]	0.26	0.30	0.28	
External diameter [mm]	32	32.3	32.15	
Thickness [mm]	3.0	3.4	3.2	

Property	Value	Test method
Minimum Required Strength (MRS)	10 MPa	EN ISO 9080
Compound density	≥ 930 kg/m ³	EN ISO 1183
Oxidation induction time (OIT)	≥ 20 min	EN ISO 11357-6
Colour	Black with external orange layer or external orange/yellow stripes	
Melt mass flow rate (MFR)	0,2 ≤ MFR ≤ 1,4	EN ISO 1133-1
Water Content	≤ 300 mg/kg	EN ISO 15512
Carbon Black content	2 to 2,5 % by mass	ISO 6964
Carbon Black or pigment dispersion	Grade ≤ 3	ISO 18553
Minimum operating temperature	- 20°C	UNI EN 1555-2
Maximum operating temperature	40°C	UNI EN 1555-2
Hydrostatic Strenght (80°C; 165 h)	5,4 MPa	EN ISO 1167
Elongation at break	≥ 350 %	EN ISO 6259
Longitudinal Reversion	≤ 3 %	EN ISO 2505
Minimum Tensile Strain at yield	19 MPa	EN ISO 6259
Flexural modulus	> 900 MPa	EN ISO 178
Coefficient of Thermal Linear Expansion	0,22 mm/m/°C	

CENTRALTUBI GAS DE50 SDR11 S5

Minimum and maximum values referring to the pipes characteristics refers to the values given by the reference standard and relies on the data variability. Different ID represents the same pipe with different colouring: differed colour tubes are produced in the same way; the difference in colour defines their different function (gas pipe, water pipe, etc.) and is used solely for distinguishing them logistically; they do not affect the products' environmental performance.

Property	Value			Notes
Product ID	GHUI005000S5 GHNf005000S5 GEDI005000S5 GMDP005000S5			PE100 Black with yellow external stripes PE100 Black with orange external stripes PE100 RC Black with orange external stripes PE100 RC Black with orange external layer
Pipe material	HDPE – PE100 – PE100-RC			
Content of recycled material	0%			
Number of layers	Solid wall Single or double layer of the same polymer			
Reference service life (RSL)	100 years			According to FprEN 16903 and (Ulrich Schulte and Joachim Hessel, 2006)
Mass conversion factor	0,67 kg/m			
	Min	Max	Average	
Density [kg/m ³]	956	962	959	
Weight [kg/m]	0,63	0,71	0,67	
External diameter [mm]	50	50.4	50.2	
Thickness [mm]	4.6	5.2	4.9	

Property	Value	Test method
Minimum Required Strength (MRS)	10 MPa	EN ISO 9080
Compound density	≥ 930 kg/m ³	EN ISO 1183
Oxidation induction time (OIT)	≥ 20 min	EN ISO 11357-6
Colour	Black with external orange layer or external orange/yellow stripes	
Melt mass flow rate (MFR)	0,2 ≤ MFR ≤ 1,4	EN ISO 1133-1
Water Content	≤ 300 mg/kg	EN ISO 15512
Carbon Black content	2 to 2,5 % by mass	ISO 6964
Carbon Black or pigment dispersion	Grade ≤ 3	ISO 18553
Minimum operating temperature	- 20°C	UNI EN 1555-2
Maximum operating temperature	40°C	UNI EN 1555-2
Hydrostatic Strenght (80°C; 165 h)	5,4 MPa	EN ISO 1167
Elongation at break	≥ 350 %	EN ISO 6259
Longitudinal Reversion	≤ 3 %	EN ISO 2505
Minimum Tensile Strain at yield	19 MPa	EN ISO 6259
Flexural modulus	> 900 MPa	EN ISO 178
Coefficient of Thermal Linear Expansion	0,22 mm/m/°C	

CENTRALTUBI GAS DE75 SDR11 S5

Minimum and maximum values referring to the pipes characteristics refers to the values given by the reference standard and relies on the data variability. Different ID represents the same pipe with different colouring: differed colour tubes are produced in the same way; the difference in colour defines their different function (gas pipe, water pipe, etc.) and is used solely for distinguishing them logistically; they do not affect the products' environmental performance.

Property	Value			Notes
Product ID	GHUI007500S5 GHNf007500S5 GEDI007500S5 GMdp007500S5			PE100 Black with yellow external stripes PE100 Black with orange external stripes PE100 RC Black with orange external stripes PE100 RC Black with orange external layer
Pipe material	HDPE – PE100 – PE100-RC			
Content of recycled material	0%			
Number of layers	Solid wall Single or double layer of the same polymer			
Reference service life (RSL)	100 years			According to FprEN 16903 and (Ulrich Schulte and Joachim Hessel, 2006)
Mass conversion factor	1.48 kg/m			
	Min	Max	Average	
Density [kg/m ³]	956	962	959	
Weight [kg/m]	1.39	1.56	1.48	
External diameter [mm]	75	75.5	75.25	
Thickness [mm]	6.8	7.6	7.2	

Property	Value	Test method
Minimum Required Strength (MRS)	10 MPa	EN ISO 9080
Compound density	≥ 930 kg/m ³	EN ISO 1183
Oxidation induction time (OIT)	≥ 20 min	EN ISO 11357-6
Colour	Black with external orange layer or external orange/yellow stripes	
Melt mass flow rate (MFR)	0,2 ≤ MFR ≤ 1,4	EN ISO 1133-1
Water Content	≤ 300 mg/kg	EN ISO 15512
Carbon Black content	2 to 2,5 % by mass	ISO 6964
Carbon Black or pigment dispersion	Grade ≤ 3	ISO 18553
Minimum operating temperature	- 20°C	UNI EN 1555-2
Maximum operating temperature	40°C	UNI EN 1555-2
Hydrostatic Strenght (80°C; 165 h)	5,4 MPa	EN ISO 1167
Elongation at break	≥ 350 %	EN ISO 6259
Longitudinal Reversion	≤ 3 %	EN ISO 2505
Minimum Tensile Strain at yield	19 MPa	EN ISO 6259
Flexural modulus	> 900 MPa	EN ISO 178
Coefficient of Thermal Linear Expansion	0,22 mm/m/°C	

CENTRALTUBI GAS DE110 SDR11 S5

Minimum and maximum values referring to the pipes characteristics refers to the values given by the reference standard and relies on the data variability. Different ID represents the same pipe with different colouring: differed colour tubes are produced in the same way; the difference in colour defines their different function (gas pipe, water pipe, etc.) and is used solely for distinguishing them logistically; they do not affect the products' environmental performance.

Property	Value			Notes
Product ID	GHUI011000S5 GHNFO11000S5 GEDI011000S5 GMDP011000S5			PE100 Black with yellow external stripes PE100 Black with orange external stripes PE100 RC Black with orange external stripes PE100 RC Black with orange external layer
Pipe material	HDPE – PE100 – PE100-RC			
Content of recycled material	0%			
Number of layers	Solid wall Single or double layer of the same polymer			
Reference service life (RSL)	100 years			According to FprEN 16903 and (Ulrich Schulte and Joachim Hessel, 2006)
Mass conversion factor	3.17 kg/m			
	Min	Max	Average	
Density [kg/m ³]	956	962	959	
Weight [kg/m]	3.0	3.34	3.17	
External diameter [mm]	110	110.7	110.35	
Thickness [mm]	10.0	11.1	10.55	

Property	Value	Test method
Minimum Required Strength (MRS)	10 MPa	EN ISO 9080
Compound density	≥ 930 kg/m ³	EN ISO 1183
Oxidation induction time (OIT)	≥ 20 min	EN ISO 11357-6
Colour	Black with external orange layer or external orange/yellow stripes	
Melt mass flow rate (MFR)	0,2 ≤ MFR ≤ 1,4	EN ISO 1133-1
Water Content	≤ 300 mg/kg	EN ISO 15512
Carbon Black content	2 to 2,5 % by mass	ISO 6964
Carbon Black or pigment dispersion	Grade ≤ 3	ISO 18553
Minimum operating temperature	- 20°C	UNI EN 1555-2
Maximum operating temperature	40°C	UNI EN 1555-2
Hydrostatic Strenght (80°C; 165 h)	5,4 MPa	EN ISO 1167
Elongation at break	≥ 350 %	EN ISO 6259
Longitudinal Reversion	≤ 3 %	EN ISO 2505
Minimum Tensile Strain at yield	19 MPa	EN ISO 6259
Flexural modulus	> 900 MPa	EN ISO 178
Coefficient of Thermal Linear Expansion	0,22 mm/m/°C	

CENTRALTUBI GAS DE140 SDR11 S5

Minimum and maximum values referring to the pipes characteristics refers to the values given by the reference standard and relies on the data variability. Different ID represents the same pipe with different colouring: differed colour tubes are produced in the same way; the difference in colour defines their different function (gas pipe, water pipe, etc.) and is used solely for distinguishing them logistically; they do not affect the products' environmental performance.

Property	Value			Notes
Product ID	GHUI014000S5 GHNFO14000S5 GEDI014000S5 GMDP014000S5			PE100 Black with yellow external stripes PE100 Black with orange external stripes PE100 RC Black with orange external stripes PE100 RC Black with orange external layer
Pipe material	HDPE – PE100 – PE100-RC			
Content of recycled material	0%			
Number of layers	Solid wall Single or double layer of the same polymer			
Reference service life (RSL)	100 years			According to FprEN 16903 and (Ulrich Schulte and Joachim Hessel, 2006)
Mass conversion factor	5.13 kg/m			
	Min	Max	Average	
Density [kg/m ³]	956	962	959	
Weight [kg/m]	4.86	5.40	5.13	
External diameter [mm]	140	140.9	140.45	
Thickness [mm]	12.7	14.1	13.4	

Property	Value	Test method
Minimum Required Strength (MRS)	10 MPa	EN ISO 9080
Compound density	≥ 930 kg/m ³	EN ISO 1183
Oxidation induction time (OIT)	≥ 20 min	EN ISO 11357-6
Colour	Black with external orange layer or external orange/yellow stripes	
Melt mass flow rate (MFR)	0,2 ≤ MFR ≤ 1,4	EN ISO 1133-1
Water Content	≤ 300 mg/kg	EN ISO 15512
Carbon Black content	2 to 2,5 % by mass	ISO 6964
Carbon Black or pigment dispersion	Grade ≤ 3	ISO 18553
Minimum operating temperature	- 20°C	UNI EN 1555-2
Maximum operating temperature	40°C	UNI EN 1555-2
Hydrostatic Strenght (80°C; 165 h)	5,4 MPa	EN ISO 1167
Elongation at break	≥ 350 %	EN ISO 6259
Longitudinal Reversion	≤ 3 %	EN ISO 2505
Minimum Tensile Strain at yield	19 MPa	EN ISO 6259
Flexural modulus	> 900 MPa	EN ISO 178
Coefficient of Thermal Linear Expansion	0,22 mm/m/°C	

CENTRALTUBI GAS DE160 SDR11 S5

Minimum and maximum values referring to the pipes characteristics refers to the values given by the reference standard and relies on the data variability. Different ID represents the same pipe with different colouring: differed colour tubes are produced in the same way; the difference in colour defines their different function (gas pipe, water pipe, etc.) and is used solely for distinguishing them logistically; they do not affect the products' environmental performance.

Property	Value			Notes
Product ID	GHUI016000S5 GHNFO16000S5 GEDI016000S5 GMDP016000S5			PE100 Black with yellow external stripes PE100 Black with orange external stripes PE100 RC Black with orange external stripes PE100 RC Black with orange external layer
Pipe material	HDPE – PE100 – PE100-RC			
Content of recycled material	0%			
Number of layers	Solid wall Single or double layer of the same polymer			
Reference service life (RSL)	100 years			According to FprEN 16903 and (Ulrich Schulte and Joachim Hessel, 2006)
Mass conversion factor	6.73 kg/m			
	Min	Max	Average	
Density [kg/m ³]	956	962	959	
Weight [kg/m]	6.38	7.09	6.73	
External diameter [mm]	160	161	160.5	
Thickness [mm]	14.6	16.2	15.4	

Property	Value	Test method
Minimum Required Strength (MRS)	10 MPa	EN ISO 9080
Compound density	≥ 930 kg/m ³	EN ISO 1183
Oxidation induction time (OIT)	≥ 20 min	EN ISO 11357-6
Colour	Black with external orange layer or external orange/yellow stripes	
Melt mass flow rate (MFR)	0,2 ≤ MFR ≤ 1,4	EN ISO 1133-1
Water Content	≤ 300 mg/kg	EN ISO 15512
Carbon Black content	2 to 2,5 % by mass	ISO 6964
Carbon Black or pigment dispersion	Grade ≤ 3	ISO 18553
Minimum operating temperature	- 20°C	UNI EN 1555-2
Maximum operating temperature	40°C	UNI EN 1555-2
Hydrostatic Strenght (80°C; 165 h)	5,4 MPa	EN ISO 1167
Elongation at break	≥ 350 %	EN ISO 6259
Longitudinal Reversion	≤ 3 %	EN ISO 2505
Minimum Tensile Strain at yield	19 MPa	EN ISO 6259
Flexural modulus	> 900 MPa	EN ISO 178
Coefficient of Thermal Linear Expansion	0,22 mm/m/°C	

CENTRALTUBI GAS DE200 SDR11 S5

Minimum and maximum values referring to the pipes characteristics refers to the values given by the reference standard and relies on the data variability. Different ID represents the same pipe with different colouring: differed colour tubes are produced in the same way; the difference in colour defines their different function (gas pipe, water pipe, etc.) and is used solely for distinguishing them logistically; they do not affect the products' environmental performance.

Property	Value			Notes
Product ID	GHUI020000S5 GEDI020000S5 GMDP020000S5			PE100 Black with orange external stripes PE100 RC Black with orange external stripes PE100 RC Black with orange external layer
Pipe material	HDPE – PE100 – PE100-RC			
Content of recycled material	0%			
Number of layers	Solid wall Single or double layer of the same polymer			
Reference service life (RSL)	100 years			According to FprEN 16903 and (Ulrich Schulte and Joachim Hessel, 2006)
Mass conversion factor	10.49 kg/m			
	Min	Max	Average	
Density [kg/m ³]	956	962	959	
Weight [kg/m]	9.94	11.05	10.49	
External diameter [mm]	200	201.2	200.6	
Thickness [mm]	18.2	20.2	19.2	

Property	Value	Test method
Minimum Required Strength (MRS)	10 MPa	EN ISO 9080
Compound density	≥ 930 kg/m ³	EN ISO 1183
Oxidation induction time (OIT)	≥ 20 min	EN ISO 11357-6
Colour	Black with external orange layer or external orange/yellow stripes	
Melt mass flow rate (MFR)	0,2 ≤ MFR ≤ 1,4	EN ISO 1133-1
Water Content	≤ 300 mg/kg	EN ISO 15512
Carbon Black content	2 to 2,5 % by mass	ISO 6964
Carbon Black or pigment dispersion	Grade ≤ 3	ISO 18553
Minimum operating temperature	- 20°C	UNI EN 1555-2
Maximum operating temperature	40°C	UNI EN 1555-2
Hydrostatic Strenght (80°C; 165 h)	5,4 MPa	EN ISO 1167
Elongation at break	≥ 350 %	EN ISO 6259
Longitudinal Reversion	≤ 3 %	EN ISO 2505
Minimum Tensile Strain at yield	19 MPa	EN ISO 6259
Flexural modulus	> 900 MPa	EN ISO 178
Coefficient of Thermal Linear Expansion	0,22 mm/m/°C	

CENTRALTUBI GAS DE280 SDR11 S5

Minimum and maximum values referring to the pipes characteristics refers to the values given by the reference standard and relies on the data variability. Different ID represents the same pipe with different colouring: differed colour tubes are produced in the same way; the difference in colour defines their different function (gas pipe, water pipe, etc.) and is used solely for distinguishing them logistically; they do not affect the products' environmental performance.

Property	Value			Notes
Product ID	GHUI028000S5 GEDI028000S5 GMDP028000S5			PE100 Black with orange external stripes PE100 RC Black with orange external stripes PE100 RC Black with orange external layer
Pipe material	HDPE – PE100 – PE100-RC			
Content of recycled material	0%			
Number of layers	Solid wall Single or double layer of the same polymer			
Reference service life (RSL)	100 years			According to FprEN 16903 and (Ulrich Schulte and Joachim Hessel, 2006)
Mass conversion factor	20.48 kg/m			
	Min	Max	Average	
Density [kg/m ³]	956	962	959	
Weight [kg/m]	19.42	21.54	20.48	
External diameter [mm]	280	281.7	280.85	
Thickness [mm]	25.4	28.1	26.75	

Property	Value	Test method
Minimum Required Strength (MRS)	10 MPa	EN ISO 9080
Compound density	≥ 930 kg/m ³	EN ISO 1183
Oxidation induction time (OIT)	≥ 20 min	EN ISO 11357-6
Colour	Black with external orange layer or external orange/yellow stripes	
Melt mass flow rate (MFR)	0,2 ≤ MFR ≤ 1,4	EN ISO 1133-1
Water Content	≤ 300 mg/kg	EN ISO 15512
Carbon Black content	2 to 2,5 % by mass	ISO 6964
Carbon Black or pigment dispersion	Grade ≤ 3	ISO 18553
Minimum operating temperature	- 20°C	UNI EN 1555-2
Maximum operating temperature	40°C	UNI EN 1555-2
Hydrostatic Strenght (80°C; 165 h)	5,4 MPa	EN ISO 1167
Elongation at break	≥ 350 %	EN ISO 6259
Longitudinal Reversion	≤ 3 %	EN ISO 2505
Minimum Tensile Strain at yield	19 MPa	EN ISO 6259
Flexural modulus	> 900 MPa	EN ISO 178
Coefficient of Thermal Linear Expansion	0,22 mm/m/°C	

CENTRALTUBI GAS DE355 SDR11 S5

Minimum and maximum values referring to the pipes characteristics refers to the values given by the reference standard and relies on the data variability. Different ID represents the same pipe with different colouring: differed colour tubes are produced in the same way; the difference in colour defines their different function (gas pipe, water pipe, etc.) and is used solely for distinguishing them logistically; they do not affect the products' environmental performance.

Property	Value			Notes
Product ID	GHUI035500S5 GEDI035500S5 GMDP035500S5			PE100 Black with orange external stripes PE100 RC Black with orange external stripes PE100 RC Black with orange external layer
Pipe material	HDPE – PE100 – PE100-RC			
Content of recycled material	0%			
Number of layers	Solid wall Single or double layer of the same polymer			
Reference service life (RSL)	100 years			According to FprEN 16903 and (Ulrich Schulte and Joachim Hessel, 2006)
Mass conversion factor	33.00 kg/m			
	Min	Max	Average	
Density [kg/m ³]	956	962	959	
Weight [kg/m]	31.30	34.69	33.00	
External diameter [mm]	355	357.2	356.1	
Thickness [mm]	32.3	35.7	34.0	

Property	Value	Test method
Minimum Required Strength (MRS)	10 MPa	EN ISO 9080
Compound density	≥ 930 kg/m ³	EN ISO 1183
Oxidation induction time (OIT)	≥ 20 min	EN ISO 11357-6
Colour	Black with external orange layer or external orange/yellow stripes	
Melt mass flow rate (MFR)	0,2 ≤ MFR ≤ 1,4	EN ISO 1133-1
Water Content	≤ 300 mg/kg	EN ISO 15512
Carbon Black content	2 to 2,5 % by mass	ISO 6964
Carbon Black or pigment dispersion	Grade ≤ 3	ISO 18553
Minimum operating temperature	- 20°C	UNI EN 1555-2
Maximum operating temperature	40°C	UNI EN 1555-2
Hydrostatic Strenght (80°C; 165 h)	5,4 MPa	EN ISO 1167
Elongation at break	≥ 350 %	EN ISO 6259
Longitudinal Reversion	≤ 3 %	EN ISO 2505
Minimum Tensile Strain at yield	19 MPa	EN ISO 6259
Flexural modulus	> 900 MPa	EN ISO 178
Coefficient of Thermal Linear Expansion	0,22 mm/m/°C	

5. Production processes description

Production processes description

The principal aspects of a solid wall polyethylene pipe manufacturing facility are presented in the figure below.

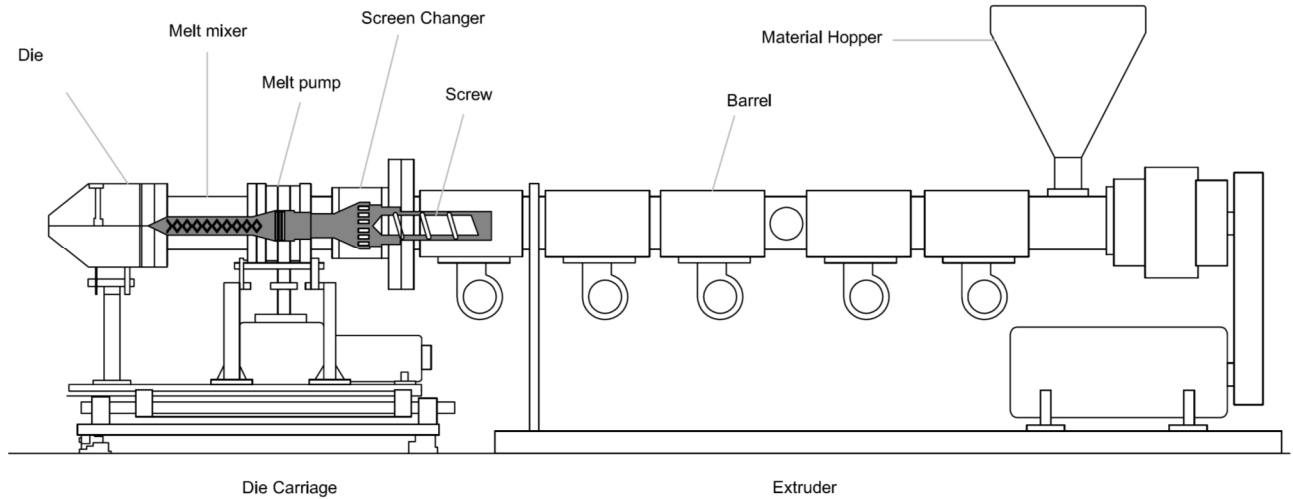

The raw material in granules is supplied in pre coloured form according with the specifications of the product standard EN 1555-1, the colours are black, orange and yellow for gas applications. After the material passes the resin's manufacturer quality control tests, it is shipped to Centraletubi in 30 ton capacity bulk trucks as loose material or in bags of 25 kg each one, dispatched on pallets.

The quality plan Centraletubi establishes specification requirements of the quality control procedure for testing incoming resins. Resins is pneumatically conveyed from the bulk transporters to silos at the plant site. The resin is then transferred from the silos to the pipe extruder by a vacuum transfer system. Polyethylene is not hygroscopic but to ensure finished product quality the resin should be dried prior to extrusion and then pass directly into the hooper above the extruder.

The function of an extruder is to heat, melt, mix and convey the material to the die, where it is shaped into a pipe. The extruder is used to heat the raw material and then force the resulting melted polymer through the pipe extrusion die. During the manufacturing process, the major portion of the heat supplied to the polymer is provided by the motor. The temperature of the extruder melted polymer is usually between 200 and 230 °C, and under high pressure (180 – 280 bar). The molten polymer goes to a screen pack to prevent the presence of foreign contaminants from entering the pipe wall and to help to homogenize the polymer.



The pipe extrusion die supports and distributes the homogeneous polymer melt around a solid mandrel, which forms it into an annular shape for solid wall pipe.

The dimension and tolerance of the pipe are determined and set during the sizing and cooling operation. For solid wall pipe, the process is accomplished by drawing the hot material from the die through a sizing sleeve and into a cooling tank, sizing may be done by using either vacuum or pressure techniques. The outside surface of the pipe is held against the sizing sleeve by vacuum. After the pipe exits the vacuum sizing tank, it is moved through a series of spray or immersion cooling tanks. Cooling water temperature are typically in the optimum range of 5 – 10 °C. The total length of the cooling baths must be adequate to cool the pipe below 85°C, in order to withstand the subsequent handling operations. A puller provide the necessary force to pull the pipe through the entire cooling operation, it also maintains the proper wall thickness control by providing a constant pulling rate. The rate at which the pipe is pulled, in combination with the extruder screw speed, determines the wall thickness of the finished pipe.

Pipes with external diameter up to 110 mm can be coiled for handling and shipping convenience. Some equipments allows the pipe to be coiled in various lengths. Pipes can also be cut into specific lengths up to 20 m. At the end of the line of production the procedure of quality control start according with the specific plan and standard reference.

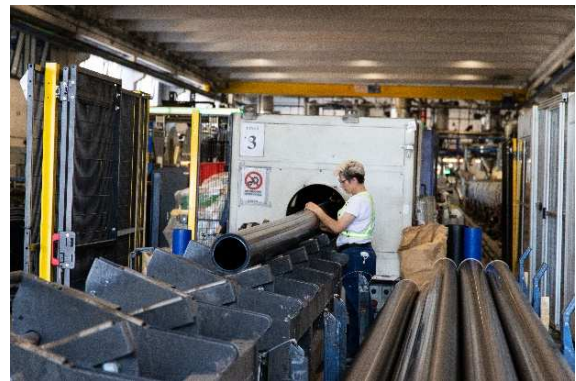

Products distribution, installation and use

Pipes are produced and delivered in different dimensions with appropriate packaging for the transport. The packaging is composed by LDPE caps, steel or PET strips and wood slats.

Installation

Ancillary materials, bedding and backfilling materials, and diesel are used during the installation phase. The functional unit of a PE underground system of 100 m, for gas distribution includes the following materials:

Polyethylene MRS 10 MPa in accordance with EN 1555,

Electrofusion fittings

Tapping Tee, coupler, flange (included nuts, bolts, washes and gaskets), 45° elbow, 90° elbow.

Diesel used during the installation phase.

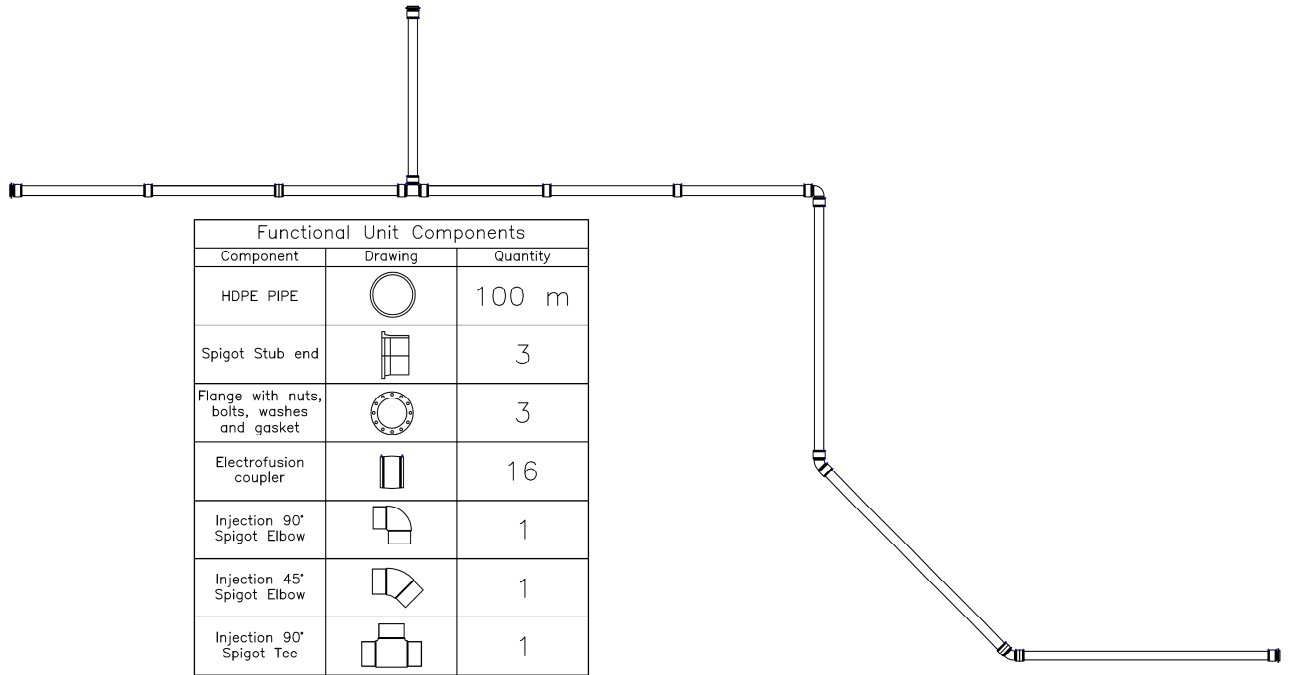

The installation method considered in the study was the open trench method and the pipes' left over related to installation is 2%.

The following figure shows the trench and the backfilling materials considered.

According with the technical literature (e.g. "Handbook of polyethylene pipes" Plastic Pipe Institute) soil and embedment materials have a range of density; in this calculation these values have been considered: sand and gravel: 1700 kg/m³; excavated soil: 2000 kg/m³. Concrete: 1440 kg/m³. Bitumen: 1050 kg/m³.

Use

Operational use (pumping energy) is not relevant for the EPD, since it falls outside the system boundaries of the LCA project. Maintenance is not needed for the HDPE pipes systems. According to PREN 16904:2021 a general scenario of zero impact for plastic piping systems inside the building is considered.

Reference service life

The service lifetime of 100 years is considered according to relevant international publication on this item (FprEN 16903 and Ulrich Schulte and Joachim Hessel, 2006).

Colouring

The colour utilized for the different products is necessary for a logistical differentiation between the various functions that the same tube can perform: differed colour tubes are produced in the same way; the difference in colour defines their different function (gas pipe, water pipe, etc.) and is used solely for distinguishing them logistically.

Products end of life

Since the gas infrastructure is a crucial asset, the replacement of an existing system with a new one end of life scenario is chosen. For the definition of the end-of-life treatment of substituted pipes and leftovers the data reported in latest version of Annex C to the PEF/OEF Methods for the specific application/material are considered (22.5% recycled, and a subdivision between incineration and landfill respectively equal to 35% and 65%). Also for the end of life of the packaging materials the data reported in latest version of Annex C to the PEF/OEF Methods for the specific application/material are considered, an exception is represented by the wood packaging: this material is not present in the Annex C to the PEF/OEF Methods materials' list, in this case the latest data from Eurostat¹ are taken into account.

Ancillary elements' end of life depends on the type of material they are made of according to latest version of Annex C to the PEF/OEF Methods: plastic elements are assumed to have the same end of life as substituted pipes and leftovers, 95% of metals are recycled while 5% are landfilled, rubber is assumed to be fully incinerated. For the incineration process, energy recovery (both thermal and electricity) is taken into account.

Bedding and backfilling materials are assumed treated in a landfill for inert materials.

Functional unit

The functional unit is defined as **1 m polyethylene pipe produced** for the conveyance of fluids under pressure.

¹ https://ec.europa.eu/eurostat/databrowser/view/env_wastrt_custom_9411639/default/table?lang=en

6. LCA results – Environmental impact per functional unit

The tables below show the results of the LCA (Life Cycle Assessment), expressed per functional unit for each pipe. Additional environmental impact indicators have been calculated but are not declared according to EN 15804+A2:2019 chapter 7.2.3.2.

CENTRALTUBI GAS DE20 S5

CORE ENVIRONMENTAL IMPACT INDICATORS

INDICATOR	UNIT		A1	A2	A3	A4	A5	B1-B7	C1	C2	C3	C4	D
Global Warming Potential (GWP)	Fossil	kg CO ₂ eq.	3,65E-01	2,12E-02	2,16E-02	1,79E-02	5,51E+01	0	0	8,12E-03	1,40E-01	1,08E-02	-1,52E-01
	Biogenic	kg CO ₂ eq.	4,42E-04	6,25E-06	1,15E-05	5,28E-06	3,59E-02	0	0	0,00E+00	2,36E-06	9,80E-07	5,40E-06
	LULUC	kg CO ₂ eq.	1,01E-04	1,00E-05	1,71E-05	8,49E-06	2,95E-02	0	0	0,00E+00	3,97E-06	3,90E-07	7,71E-07
	TOTAL	kg CO₂ eq.	3,65E-01	2,12E-02	2,16E-02	1,79E-02	5,51E+01	0	0	8,13E-03	1,40E-01	1,08E-02	-1,52E-01
Acidification (AP)	mol H ⁺ eq.		1,30E-03	8,80E-05	9,64E-05	7,45E-05	2,64E-01	0	0	3,36E-05	1,82E-05	7,32E-06	-5,80E-04
Eutrophication - freshwater (EP-freshwater)	kg P eq.		5,38E-06	1,73E-07	3,40E-07	1,46E-07	6,84E-04	0	0	6,54E-08	1,76E-08	1,54E-08	-2,68E-06
Eutrophication - marine (EP-marine)	kg N eq.		2,27E-04	3,31E-05	3,30E-05	2,80E-05	8,56E-02	0	0	1,27E-05	8,65E-06	4,79E-06	-8,96E-05
Eutrophication terrestrial (EP)	mol N eq.		2,50E-03	3,56E-04	3,73E-04	3,01E-04	9,33E-01	0	0	1,37E-04	9,38E-05	2,88E-05	-1,06E-03
Ozone depletion layer (ODP)	kg CFC-11 eq.		1,37E-08	4,67E-10	4,61E-10	3,95E-10	1,19E-06	0	0	1,78E-10	3,78E-11	2,36E-11	-7,43E-09
Photochemical ozone formation (POCP)	kg NMVOC eq.		1,27E-03	1,34E-04	1,30E-04	1,13E-04	3,40E-01	0	0	4,92E-05	2,33E-05	1,24E-05	-5,49E-04
Depletion of abiotic resources (ADP) - Minerals and metals ²	kg Sb eq.		1,45E-06	5,77E-08	1,12E-07	4,87E-08	2,13E-04	0	0	2,62E-08	2,86E-09	2,12E-09	-2,18E-06
Depletion of abiotic resources (ADP) - Fossil fuels ²	MJ, net calorific value		1,22E+01	3,12E-01	3,04E-01	2,64E-01	9,59E+02	0	0	1,16E-01	1,31E-02	2,19E-02	-3,79E+00
Water use [WDP] ²	m ³ eq.		2,56E-01	1,49E-03	2,43E-03	1,26E-03	2,78E+01	0	0	4,72E-04	2,28E-04	9,20E-04	-8,55E-02

² The results of this environmental impact indicator shall be used with care as the uncertainties on these results are high or as there is limited experienced with the indicator.

ADDITIONAL ENVIRONMENTAL IMPACT INDICATORS

INDICATOR	UNIT	A1	A2	A3	A4	A5	B1-B7	C1	C2	C3	C4	D
Particulate Matter (PM) emissions	Disease incidence	1,28E-08	2,18E-09	1,82E-09	1,85E-09	4,49E-06	0	0	6,63E-10	8,16E-11	1,54E-10	-4,46E-09
Ionizing radiation (IRP), human health ¹	kBq U235 eq.	7,30E-03	1,50E-04	2,04E-04	1,27E-04	5,59E-01	0	0	5,81E-05	6,09E-06	1,20E-05	-1,15E-03
Eco-toxicity (freshwater) ² (ETP-fw)	CTUe	5,92E-01	1,50E-01	1,22E-01	1,27E-01	4,26E+02	0	0	5,72E-02	3,08E-02	1,63E-02	-2,78E-01
Human toxicity, cancer effects ² (HTP-c)	CTUh	8,37E-11	9,24E-12	2,56E-11	7,81E-12	2,71E-08	0	0	3,71E-12	4,82E-12	5,98E-13	2,41E-10
Human toxicity, non-cancer effects ² (HTP-nc)	CTUh	1,85E-09	2,24E-10	2,37E-10	1,90E-10	5,19E-07	0	0	8,16E-11	2,10E-10	2,33E-11	-2,08E-09
Land use related impacts/Soil quality ²	-	3,98E-01	3,17E-01	7,21E-01	2,68E-01	7,63E+02	0	0	6,90E-02	3,60E-03	4,94E-02	-1,07E-01

¹ This impact category deals mainly with the eventual impact of low dose ionizing radiation on human health of the nuclear fuel cycle. It does not consider effects due to possible nuclear accidents, occupational exposure nor due to radioactive waste disposal in underground facilities. Potential ionizing radiation from the soil, from radon and from some construction materials is also not measured by this indicator.

² The results of this environmental impact indicator shall be used with care as the uncertainties on these results are high or as there is limited experience with the indicator.

PARAMETERS DESCRIBING RESOURCE USE

INDICATOR	UNIT		A1	A2	A3	A4	A5	B1-B7	C1	C2	C3	C4	D
Use of primary energy resources - Renewable	Used as energy carrier	MJ, net calorific value	1,51E-01	3,55E-03	5,80E-03	3,00E-03	1,34E+01	0	0	1,36E-03	2,07E-04	3,12E-04	-1,50E-01
	Used as raw material	MJ, net calorific value	7,47E-02	1,03E-03	9,74E-02	8,67E-04	8,62E+00	0	0	4,39E-04	1,08E-04	9,08E-05	-1,72E-01
	TOTAL	MJ, net calorific value	2,25E-01	4,57E-03	1,03E-01	3,86E-03	2,20E+01	0	0	1,80E-03	3,16E-04	4,03E-04	-1,73E-01
Use of primary energy resources - Non renewable	Used as energy carrier	MJ, net calorific value	2,70E+00	3,32E-01	3,23E-01	2,81E-01	9,37E+02	0	0	1,23E-01	1,42E-02	2,33E-02	-9,89E+00
	Used as raw material	MJ, net calorific value	1,04E+01	0	0	0	8,36E+01	0	0	0	0	0	0
	TOTAL	MJ, net calorific value	1,31E+01	3,32E-01	3,23E-01	2,81E-01	1,02E+03	0	0	1,23E-01	1,42E-02	2,33E-02	-9,89E+00
Use of secondary material	kg		0	0	0	0	0	0	0	0	0	0	0
Use of renewable secondary fuels	MJ, net calorific value		0	0	0	0	0	0	0	0	0	0	0
Use of non-renewable secondary fuels	MJ, net calorific value		0	0	0	0	0	0	0	0	0	0	0
Net use of fresh water	m ³		3,51E-03	4,58E-05	7,21E-05	3,87E-05	6,84E-01	0	0	1,55E-05	1,46E-05	2,21E-05	-1,46E-03

OTHER ENVIRONMENTAL INFORMATION DESCRIBING WASTE CATEGORIES

INDICATOR	UNIT	A1	A2	A3	A4	A5	B1-B7	C1	C2	C3	C4	D
Hazardous waste disposed	kg	9,33E-05	8,69E-06	2,29E-05	7,35E-06	2,73E-02	0	0	2,87E-06	1,04E-03	9,07E-07	3,49E-04
Non-hazardous waste disposed	kg	1,18E-02	2,73E-02	1,50E-02	2,32E-02	7,61E+02	0	0	5,66E-03	1,35E-03	8,60E-02	-5,14E-03
Radioactive waste disposed	kg	5,78E-06	9,53E-08	1,38E-07	8,05E-08	3,59E-04	0	0	3,77E-08	4,00E-09	7,33E-09	-9,79E-07

ENVIRONMENTAL INFORMATION DESCRIBING OUTPUT FLOWS

INDICATOR	UNIT	A1	A2	A3	A4	A5	B1-B7	C1	C2	C3	C4	D
Components for re-use	kg	0	0	0	0	0	0	0	0	0,00E+00	0	0
Materials for recycling	kg	0	0	1,06E-02	0	1,01E-03	0	0	0	6,43E-02	0	0
Materials for energy recovery	kg	0	0	0	0	0	0	0	0	0,00E+00	0	0
Exported electricity	MJ	0	0	0	0	6,56E-03	0	0	0	3,17E-01	0	0
Exported thermal energy	MJ	0	0	0	0	1,31E-02	0	0	0	6,35E-01	0	0

BIOGENIC CARBON CONTENT

INDICATOR	UNIT	TOTAL
Biogenic carbon content	kg C	0

CENTRALTUBI GAS DE32 S5 SDR11

CORE ENVIRONMENTAL IMPACT INDICATORS

INDICATOR	UNIT		A1	A2	A3	A4	A5	B1-B7	C1	C2	C3	C4	D
Global Warming Potential (GWP)	Fossil	kg CO ₂ eq.	6,37E-01	3,71E-02	3,77E-02	1,39E-02	5,73E+01	0	0	1,30E-02	2,46E-01	1,90E-02	-2,52E-01
	Biogenic	kg CO ₂ eq.	7,72E-04	1,09E-05	2,02E-05	4,08E-06	3,75E-02	0	0	3,78E-06	1,71E-06	9,52E-06	7,97E-04
	LULUC	kg CO ₂ eq.	1,76E-04	1,76E-05	2,98E-05	6,58E-06	3,07E-02	0	0	6,38E-06	6,77E-07	1,36E-06	-1,86E-05
	TOTAL	kg CO₂ eq.	6,38E-01	3,71E-02	3,78E-02	1,39E-02	5,73E+01	0	0	1,31E-02	2,46E-01	1,90E-02	-2,52E-01
Acidification (AP)	mol H+ eq.		2,26E-03	1,54E-04	1,69E-04	5,84E-05	2,75E-01	0	0	5,40E-05	3,18E-05	1,29E-05	-9,70E-04
Eutrophication - freshwater (EP-freshwater)	kg P eq.		9,37E-06	3,02E-07	5,95E-07	1,13E-07	7,11E-04	0	0	1,05E-07	3,07E-08	2,70E-08	-4,11E-06
Eutrophication - marine (EP-marine)	kg N eq.		3,96E-04	5,79E-05	5,77E-05	2,18E-05	8,92E-02	0	0	2,04E-05	1,52E-05	8,44E-06	-1,45E-04
Eutrophication terrestrial (EP)	mol N eq.		4,36E-03	6,23E-04	6,53E-04	2,35E-04	9,71E-01	0	0	2,20E-04	1,64E-04	5,07E-05	-1,71E-03
Ozone depletion layer (ODP)	kg CFC-11 eq.		1,89E-08	8,16E-10	8,07E-10	3,05E-10	1,23E-06	0	0	2,86E-10	6,48E-11	4,15E-11	-1,06E-08
Photochemical ozone formation (POCP)	kg NMVOC eq.		2,23E-03	2,34E-04	2,28E-04	8,80E-05	3,54E-01	0	0	7,91E-05	4,08E-05	2,19E-05	-8,86E-04
Depletion of abiotic resources (ADP) - Minerals and metals ²	kg Sb eq.		2,53E-06	1,01E-07	1,97E-07	3,76E-08	2,23E-04	0	0	4,22E-08	4,98E-09	3,73E-09	-3,88E-06
Depletion of abiotic resources (ADP) - Fossil fuels ²	MJ, net calorific value		2,13E+01	5,46E-01	5,32E-01	2,04E-01	9,96E+02	0	0	1,86E-01	2,28E-02	3,85E-02	-6,52E+00
Water use [WDP] ²	m ³ eq.		4,47E-01	2,61E-03	4,25E-03	9,74E-04	2,91E+01	0	0	7,59E-04	3,84E-04	1,62E-03	-1,49E-01

² The results of this environmental impact indicator shall be used with care as the uncertainties on these results are high or as there is limited experienced with the indicator.

ADDITIONAL ENVIRONMENTAL IMPACT INDICATORS

INDICATOR	UNIT	A1	A2	A3	A4	A5	B1-B7	C1	C2	C3	C4	D
Particulate Matter (PM) emissions	Disease incidence	2,23E-08	3,82E-09	3,18E-09	1,43E-09	4,67E-06	0	0	1,07E-09	1,43E-10	2,71E-10	-6,86E-09
Ionizing radiation (IRP), human health ¹	kBq U235 eq.	1,27E-02	2,63E-04	3,57E-04	9,81E-05	5,81E-01	0	0	9,33E-05	1,04E-05	2,11E-05	-2,22E-03
Eco-toxicity (freshwater) ² (ETP-fw)	CTUe	1,03E+00	2,63E-01	2,14E-01	9,81E-02	4,42E+02	0	0	9,18E-02	5,17E-02	2,87E-02	-4,90E-01
Human toxicity, cancer effects ² (HTP-c)	CTUh	1,46E-10	1,62E-11	4,48E-11	6,04E-12	2,82E-08	0	0	5,96E-12	8,48E-12	1,05E-12	2,86E-10
Human toxicity, non-cancer effects ² (HTP-nc)	CTUh	3,22E-09	3,92E-10	4,14E-10	1,46E-10	5,41E-07	0	0	1,31E-10	3,70E-10	4,11E-11	-3,74E-09
Land use related impacts/Soil quality ²	-	6,92E-01	5,54E-01	1,26E+00	2,07E-01	7,99E+02	0	0	1,11E-01	6,27E-03	8,69E-02	-1,50E-01

¹ This impact category deals mainly with the eventual impact of low dose ionizing radiation on human health of the nuclear fuel cycle. It does not consider effects due to possible nuclear accidents, occupational exposure nor due to radioactive waste disposal in underground facilities. Potential ionizing radiation from the soil, from radon and from some construction materials is also not measured by this indicator.

² The results of this environmental impact indicator shall be used with care as the uncertainties on these results are high or as there is limited experienced with the indicator.

PARAMETERS DESCRIBING RESOURCE USE

INDICATOR	UNIT		A1	A2	A3	A4	A5	B1-B7	C1	C2	C3	C4	D
Use of primary energy resources - Renewable	Used as energy carrier	MJ, net calorific value	2,63E-01	6,20E-03	1,01E-02	2,31E-03	1,39E+01	0	0	2,18E-03	3,56E-04	5,50E-04	-2,55E-01
	Used as raw material	MJ, net calorific value	1,30E-01	1,80E-03	1,71E-01	6,70E-04	8,92E+00	0	0	7,05E-04	1,88E-04	1,60E-04	-2,16E-01
	TOTAL	MJ, net calorific value	3,93E-01	8,00E-03	1,81E-01	2,98E-03	2,28E+01	0	0	2,89E-03	5,44E-04	7,10E-04	-2,95E-01
Use of primary energy resources - Non renewable	Used as energy carrier	MJ, net calorific value	4,72E+00	5,80E-01	5,66E-01	2,17E-01	9,73E+02	0	0	1,98E-01	2,48E-02	4,10E-02	-1,39E+01
	Used as raw material	MJ, net calorific value	1,81E+01	0	0	0	8,65E+01	0	0	0	0	0	0
	TOTAL	MJ, net calorific value	2,28E+01	5,80E-01	5,66E-01	2,17E-01	1,06E+03	0	0	1,98E-01	2,48E-02	4,10E-02	-1,39E+01
Use of secondary material	kg		0	0	0	0	0	0	0	0	0	0	0
Use of renewable secondary fuels	MJ, net calorific value		0	0	0	0	0	0	0	0	0	0	0
Use of non-renewable secondary fuels	MJ, net calorific value		0	0	0	0	0	0	0	0	0	0	0
Net use of fresh water	m ³		6,13E-03	8,01E-05	1,26E-04	2,99E-05	7,15E-01	0	0	2,49E-05	2,36E-05	3,88E-05	-2,50E-03

OTHER ENVIRONMENTAL INFORMATION DESCRIBING WASTE CATEGORIES

INDICATOR	UNIT	A1	A2	A3	A4	A5	B1-B7	C1	C2	C3	C4	D
Hazardous waste disposed	kg	1,63E-04	1,52E-05	4,00E-05	5,68E-06	2,84E-02	0	0	4,61E-06	1,82E-03	1,60E-06	6,12E-04
Non-hazardous waste disposed	kg	2,06E-02	4,78E-02	2,63E-02	1,79E-02	7,93E+02	0	0	9,10E-03	2,34E-03	1,51E-01	-4,51E-03
Radioactive waste disposed	kg	1,01E-05	1,67E-07	2,42E-07	6,21E-08	3,74E-04	0	0	6,05E-08	6,82E-09	1,29E-08	-1,90E-06

ENVIRONMENTAL INFORMATION DESCRIBING OUTPUT FLOWS

INDICATOR	UNIT	A1	A2	A3	A4	A5	B1-B7	C1	C2	C3	C4	D
Components for re-use	kg	0	0	0	0	0	0	0	0	0	0	0
Materials for recycling	kg	0	0	1,86E-02	0	1,64E-03	0	0	0	1,00E-01	0	0
Materials for energy recovery	kg	0	0	0	0	0,00E+00	0	0	0	0	0	0
Exported electricity	MJ	0	0	0	0	1,13E-02	0	0	0	5,55E-01	0	0
Exported thermal energy	MJ	0	0	0	0	2,26E-02	0	0	0	1,11E+00	0	0

BIOGENIC CARBON CONTENT

INDICATOR	UNIT	TOTAL
Biogenic carbon content	kg C	0

CENTRALTUBI GAS DE50 S5 SDR11

CORE ENVIRONMENTAL IMPACT INDICATORS

INDICATOR	UNIT		A1	A2	A3	A4	A5	B1-B7	C1	C2	C3	C4	D
Global Warming Potential (GWP)	Fossil	kg CO ₂ eq.	1,52E+00	8,85E-02	9,02E-02	2,68E-02	6,07E+01	0	0	2,94E-02	5,82E-01	4,51E-02	-5,77E-01
	Biogenic	kg CO ₂ eq.	1,83E-03	2,61E-05	4,82E-05	7,88E-06	4,11E-02	0	0	8,52E-06	4,04E-06	2,26E-05	1,86E-03
	LULUC	kg CO ₂ eq.	4,17E-04	4,19E-05	7,13E-05	1,27E-05	3,25E-02	0	0	1,44E-05	1,60E-06	3,22E-06	-3,65E-05
	TOTAL	kg CO₂ eq.	1,52E+00	8,86E-02	9,03E-02	2,68E-02	6,07E+01	0,00E+00	0,00E+00	2,94E-02	5,82E-01	4,52E-02	-5,75E-01
Acidification (AP)	mol H+ eq.		5,38E-03	3,68E-04	4,03E-04	1,12E-04	2,92E-01	0	0	1,22E-04	7,52E-05	3,05E-05	-2,08E-03
Eutrophication - freshwater (EP-freshwater)	kg P eq.		2,22E-05	7,20E-07	1,42E-06	2,18E-07	7,57E-04	0	0	2,37E-07	7,25E-08	6,43E-08	-8,26E-06
Eutrophication - marine (EP-marine)	kg N eq.		9,43E-04	1,38E-04	1,38E-04	4,20E-05	9,46E-02	0	0	4,60E-05	3,59E-05	2,00E-05	-3,20E-04
Eutrophication terrestrial (EP)	mol N eq.		1,04E-02	1,49E-03	1,56E-03	4,51E-04	1,03E+00	0	0	4,95E-04	3,89E-04	1,20E-04	-3,77E-03
Ozone depletion layer (ODP)	kg CFC-11 eq.		2,77E-08	1,95E-09	1,93E-09	5,89E-10	1,31E-06	0	0	6,43E-10	1,51E-10	9,85E-11	-1,75E-08
Photochemical ozone formation (POCP)	kg NMVOC eq.		5,30E-03	5,58E-04	5,45E-04	1,69E-04	3,75E-01	0	0	1,78E-04	9,66E-05	5,19E-05	-1,97E-03
Depletion of abiotic resources (ADP) - Minerals and metals ²	kg Sb eq.		6,01E-06	2,40E-07	4,70E-07	7,27E-08	2,38E-04	0	0	9,50E-08	1,18E-08	8,86E-09	-7,10E-06
Depletion of abiotic resources (ADP) - Fossil fuels ²	MJ, net calorific value		5,07E+01	1,30E+00	1,27E+00	3,94E-01	1,05E+03	0	0	4,19E-01	5,38E-02	9,14E-02	-1,53E+01
Water use [WDP] ²	m ³ eq.		1,07E+00	6,23E-03	1,02E-02	1,88E-03	3,11E+01	0	0	1,71E-03	8,89E-04	3,84E-03	-3,51E-01

² The results of this environmental impact indicator shall be used with care as the uncertainties on these results are high or as there is limited experienced with the indicator.

ADDITIONAL ENVIRONMENTAL IMPACT INDICATORS

INDICATOR	UNIT	A1	A2	A3	A4	A5	B1-B7	C1	C2	C3	C4	D
Particulate Matter (PM) emissions	Disease incidence	5,31E-08	9,12E-09	7,60E-09	2,76E-09	4,96E-06	0	0	2,40E-09	3,37E-10	6,44E-10	-1,47E-08
Ionizing radiation (IRP), human health ¹	kBq U235 eq.	3,02E-02	6,27E-04	8,53E-04	1,90E-04	6,17E-01	0	0	2,10E-04	2,44E-05	5,02E-05	-5,41E-03
Eco-toxicity (freshwater) ² (ETP-fw)	CTUe	2,45E+00	6,27E-01	5,11E-01	1,89E-01	4,68E+02	0	0	2,07E-01	1,19E-01	6,81E-02	-9,35E-01
Human toxicity, cancer effects ² (HTP-c)	CTUh	3,47E-10	3,86E-11	1,07E-10	1,17E-11	3,04E-08	0	0	1,34E-11	2,01E-11	2,50E-12	5,31E-10
Human toxicity, non-cancer effects ² (HTP-nc)	CTUh	7,64E-09	9,36E-10	9,89E-10	2,83E-10	5,76E-07	0	0	2,95E-10	8,78E-10	9,77E-11	-6,89E-09
Land use related impacts/Soil quality ²	-	1,64E+00	1,32E+00	3,01E+00	4,00E-01	8,52E+02	0	0	2,50E-01	1,48E-02	2,06E-01	-2,55E-01

¹ This impact category deals mainly with the eventual impact of low dose ionizing radiation on human health of the nuclear fuel cycle. It does not consider effects due to possible nuclear accidents, occupational exposure nor due to radioactive waste disposal in underground facilities. Potential ionizing radiation from the soil, from radon and from some construction materials is also not measured by this indicator.

² The results of this environmental impact indicator shall be used with care as the uncertainties on these results are high or as there is limited experienced with the indicator.

PARAMETERS DESCRIBING RESOURCE USE

INDICATOR	UNIT		A1	A2	A3	A4	A5	B1-B7	C1	C2	C3	C4	D
Use of primary energy resources - Renewable	Used as energy carrier	MJ, net calorific value	6,23E-01	1,48E-02	2,42E-02	4,47E-03	1,48E+01	0	0	4,92E-03	8,34E-04	1,31E-03	-5,86E-01
	Used as raw material	MJ, net calorific value	3,09E-01	4,28E-03	4,07E-01	1,29E-03	9,40E+00	0	0	1,59E-03	4,42E-04	3,80E-04	-3,59E-01
	TOTAL	MJ, net calorific value	9,32E-01	1,91E-02	4,32E-01	5,77E-03	2,42E+01	0	0	6,51E-03	1,28E-03	1,69E-03	-6,82E-01
Use of primary energy resources - Non renewable	Used as energy carrier	MJ, net calorific value	1,12E+01	1,38E+00	1,35E+00	4,19E-01	1,03E+03	0	0	4,46E-01	5,86E-02	9,73E-02	-2,68E+01
	Used as raw material	MJ, net calorific value	4,32E+01	0	0	0	9,13E+01	0	0	0	0	0	0
	TOTAL	MJ, net calorific value	5,44E+01	1,38E+00	1,35E+00	4,19E-01	0	0	0	4,46E-01	5,86E-02	9,73E-02	-2,68E+01
Use of secondary material	kg		0	0	0	0	0	0	0	0	0	0	0
Use of renewable secondary fuels	MJ, net calorific value		0	0	0	0	0	0	0	0	0	0	0
Use of non-renewable secondary fuels	MJ, net calorific value		0	0	0	0	0	0	0	0	0	0	0
Net use of fresh water	m ³		1,46E-02	1,91E-04	3,01E-04	5,78E-05	7,62E-01	0	0	5,60E-05	5,31E-05	9,21E-05	-5,78E-03

OTHER ENVIRONMENTAL INFORMATION DESCRIBING WASTE CATEGORIES

INDICATOR	UNIT	A1	A2	A3	A4	A5	B1-B7	C1	C2	C3	C4	D
Hazardous waste disposed	kg	3,87E-04	3,63E-05	9,55E-05	1,10E-05	3,05E-02	0	0	1,04E-05	4,31E-03	3,80E-06	1,44E-03
Non-hazardous waste disposed	kg	4,88E-02	1,14E-01	6,28E-02	3,45E-02	8,43E+02	0	0	2,05E-02	5,51E-03	3,58E-01	-4,16E-03
Radioactive waste disposed	kg	2,39E-05	3,98E-07	5,77E-07	1,20E-07	3,98E-04	0	0	1,36E-07	1,59E-08	3,06E-08	-4,66E-06

ENVIRONMENTAL INFORMATION DESCRIBING OUTPUT FLOWS

INDICATOR	UNIT	A1	A2	A3	A4	A5	B1-B7	C1	C2	C3	C4	D
Components for re-use	kg	0	0	0	0	0	0	0	0	0	0	0
Materials for recycling	kg	0	0	4,45E-02	0	3,40E-03	0	0	0	2,21E-01	0	0
Materials for energy recovery	kg	0	0	0	0	0	0	0	0	0	0	0
Exported electricity	MJ	0	0	0	0	2,57E-02	0	0	0	1,31E+00	0	0
Exported thermal energy	MJ	0	0	0	0	5,14E-02	0	0	0	2,63E+00	0	0

BIOGENIC CARBON CONTENT

INDICATOR	UNIT	TOTAL
Biogenic carbon content	kg C	0

CENTRALTUBI GAS DE75 S5 SDR11

CORE ENVIRONMENTAL IMPACT INDICATORS

INDICATOR	UNIT		A1	A2	A3	A4	A5	B1-B7	C1	C2	C3	C4	D
Global Warming Potential (GWP)	Fossil	kg CO ₂ eq.	3,35E+00	1,95E-01	1,99E-01	5,65E-02	6,55E+01	0	0	6,01E-02	1,28E+00	9,97E-02	-1,21E+00
	Biogenic	kg CO ₂ eq.	4,04E-03	5,75E-05	1,06E-04	1,66E-05	4,52E-02	0	0	1,74E-05	8,87E-06	5,00E-05	4,08E-03
	LULUC	kg CO ₂ eq.	9,17E-04	9,25E-05	1,57E-04	2,69E-05	3,51E-02	0	0	2,94E-05	3,50E-06	7,10E-06	-6,62E-05
	TOTAL	kg CO₂ eq.	3,35E+00	1,95E-01	1,99E-01	5,65E-02	6,56E+01	0	0	6,01E-02	1,28E+00	9,97E-02	-1,21E+00
Acidification (AP)	mol H+ eq.		1,19E-02	8,11E-04	8,89E-04	2,45E-04	3,15E-01	0	0	2,49E-04	1,65E-04	6,73E-05	-4,18E-03
Eutrophication - freshwater (EP-freshwater)	kg P eq.		4,89E-05	1,59E-06	3,14E-06	4,58E-07	8,21E-04	0	0	4,84E-07	1,59E-07	1,42E-07	-1,49E-05
Eutrophication - marine (EP-marine)	kg N eq.		2,08E-03	3,05E-04	3,04E-04	9,06E-05	1,02E-01	0	0	9,41E-05	7,90E-05	4,42E-05	-6,47E-04
Eutrophication terrestrial (EP)	mol N eq.		2,29E-02	3,28E-03	3,44E-03	9,76E-04	1,12E+00	0	0	1,01E-03	8,56E-04	2,65E-04	-7,61E-03
Ozone depletion layer (ODP)	kg CFC-11 eq.		4,76E-08	4,30E-09	4,26E-09	1,24E-09	1,41E-06	0	0	1,31E-09	3,29E-10	2,17E-10	-3,18E-08
Photochemical ozone formation (POCP)	kg NMVOC eq.		1,17E-02	1,23E-03	1,20E-03	3,63E-04	4,06E-01	0	0	3,64E-04	2,13E-04	1,15E-04	-4,01E-03
Depletion of abiotic resources (ADP) - Minerals and metals ²	kg Sb eq.		1,32E-05	5,31E-07	1,04E-06	1,53E-07	2,60E-04	0	0	1,94E-07	2,58E-08	1,96E-08	-1,29E-05
Depletion of abiotic resources (ADP) - Fossil fuels ²	MJ, net calorific value		1,12E+02	2,87E+00	2,80E+00	8,30E-01	1,14E+03	0	0	8,57E-01	1,18E-01	2,02E-01	-3,31E+01
Water use [WDP] ²	m ³ eq.		2,35E+00	1,37E-02	2,24E-02	3,95E-03	3,39E+01	0	0	3,49E-03	1,92E-03	8,46E-03	-7,67E-01

² The results of this environmental impact indicator shall be used with care as the uncertainties on these results are high or as there is limited experienced with the indicator.

ADDITIONAL ENVIRONMENTAL IMPACT INDICATORS

INDICATOR	UNIT	A1	A2	A3	A4	A5	B1-B7	C1	C2	C3	C4	D
Particulate Matter (PM) emissions	Disease incidence	1,17E-07	2,01E-08	1,68E-08	5,79E-09	5,37E-06	0	0	4,91E-09	7,42E-10	1,42E-09	-2,81E-08
Ionizing radiation (IRP), human health ¹	kBq U235 eq.	6,65E-02	1,38E-03	1,88E-03	3,98E-04	6,70E-01	0	0	4,30E-04	5,30E-05	1,11E-04	-1,25E-02
Eco-toxicity (freshwater) ² (ETP-fw)	CTUe	5,40E+00	1,38E+00	1,13E+00	3,99E-01	5,05E+02	0	0	4,23E-01	2,56E-01	1,50E-01	-1,76E+00
Human toxicity, cancer effects ² (HTP-c)	CTUh	7,64E-10	8,51E-11	2,36E-10	2,46E-11	3,32E-08	0	0	2,75E-11	4,44E-11	5,52E-12	6,80E-10
Human toxicity, non-cancer effects ² (HTP-nc)	CTUh	1,68E-08	2,07E-09	2,18E-09	5,94E-10	6,26E-07	0	0	6,04E-10	1,94E-09	2,16E-10	-1,27E-08
Land use related impacts/Soil quality ²	-	3,60E+00	2,92E+00	6,65E+00	8,38E-01	9,29E+02	0	0	5,11E-01	3,24E-02	4,55E-01	-3,49E-01

¹ This impact category deals mainly with the eventual impact of low dose ionizing radiation on human health of the nuclear fuel cycle. It does not consider effects due to possible nuclear accidents, occupational exposure nor due to radioactive waste disposal in underground facilities. Potential ionizing radiation from the soil, from radon and from some construction materials is also not measured by this indicator.

² The results of this environmental impact indicator shall be used with care as the uncertainties on these results are high or as there is limited experienced with the indicator.

PARAMETERS DESCRIBING RESOURCE USE

INDICATOR	UNIT		A1	A2	A3	A4	A5	B1-B7	C1	C2	C3	C4	D
Use of primary energy resources - Renewable	Used as energy carrier	MJ, net calorific value	1,37E+00	3,27E-02	5,35E-02	9,39E-03	1,60E+01	0	0	1,01E-02	1,82E-03	2,88E-03	-1,25E+00
	Used as raw material	MJ, net calorific value	6,80E-01	9,45E-03	8,99E-01	2,72E-03	1,01E+01	0	0	3,25E-03	9,67E-04	8,38E-04	-6,42E-01
	TOTAL	MJ, net calorific value	2,05E+00	4,21E-02	9,53E-01	1,21E-02	2,61E+01	0	0	1,33E-02	2,79E-03	3,72E-03	-1,46E+00
Use of primary energy resources - Non renewable	Used as energy carrier	MJ, net calorific value	2,47E+01	3,06E+00	2,98E+00	8,82E-01	1,11E+03	0	0	9,11E-01	1,29E-01	2,14E-01	-5,27E+01
	Used as raw material	MJ, net calorific value	9,53E+01	0	0	0	9,92E+01	0	0	0	0	0	0
	TOTAL	MJ, net calorific value	1,20E+02	3,06E+00	2,98E+00	8,82E-01	1,21E+03	0	0	9,11E-01	1,29E-01	2,14E-01	-5,27E+01
Use of secondary material	kg		0	0	0	0	0	0	0	0	0	0	0
Use of renewable secondary fuels	MJ, net calorific value		0	0	0	0	0	0	0	0	0	0	0
Use of non-renewable secondary fuels	MJ, net calorific value		0	0	0	0	0	0	0	0	0	0	0
Net use of fresh water	m ³		3,21E-02	4,22E-04	6,65E-04	1,21E-04	8,29E-01	0	0	1,14E-04	1,12E-04	2,03E-04	-1,24E-02

OTHER ENVIRONMENTAL INFORMATION DESCRIBING WASTE CATEGORIES

INDICATOR	UNIT	A1	A2	A3	A4	A5	B1-B7	C1	C2	C3	C4	D
Hazardous waste disposed	kg	8,52E-04	8,01E-05	2,11E-04	2,30E-05	3,33E-02	0	0	2,12E-05	9,48E-03	8,38E-06	3,19E-03
Non-hazardous waste disposed	kg	1,07E-01	2,52E-01	1,39E-01	7,24E-02	9,14E+02	0	0	4,19E-02	1,21E-02	7,88E-01	9,21E-03
Radioactive waste disposed	kg	5,26E-05	8,77E-07	1,27E-06	2,52E-07	4,33E-04	0	0	2,79E-07	3,46E-08	6,76E-08	-1,09E-05

ENVIRONMENTAL INFORMATION DESCRIBING OUTPUT FLOWS

INDICATOR	UNIT	A1	A2	A3	A4	A5	B1-B7	C1	C2	C3	C4	D
Components for re-use	kg	0	0	0	0	0	0	0	0	0	0	0
Materials for recycling	kg	0	0	9,83E-02	0,00E+00	7,11E-03	0	0	0	4,37E-01	0	0
Materials for energy recovery	kg	0	0	0,00E+00	0,00E+00	0,00E+00	0	0	0	0,00E+00	0	0
Exported electricity	MJ	0	0	0,00E+00	0,00E+00	5,58E-02	0	0	0	2,89E+00	0	0
Exported thermal energy	MJ	0	0	0,00E+00	0,00E+00	1,12E-01	0	0	0	5,78E+00	0	0

BIOGENIC CARBON CONTENT

INDICATOR	UNIT	TOTAL
Biogenic carbon content	kg C	0

CENTRALTUBI GAS DE110 S5 SDR11

CORE ENVIRONMENTAL IMPACT INDICATORS

INDICATOR	UNIT		A1	A2	A3	A4	A5	B1-B7	C1	C2	C3	C4	D
Global Warming Potential (GWP)	Fossil	kg CO ₂ eq.	7,22E+00	4,20E-01	4,28E-01	1,30E-01	7,27E+01	0	0	1,25E-01	2,75E+00	2,15E-01	-2,58E+00
	Biogenic	kg CO ₂ eq.	8,89E-03	1,24E-04	2,29E-04	3,84E-05	5,26E-02	0	0	3,63E-05	1,90E-05	1,08E-04	8,57E-03
	LULUC	kg CO ₂ eq.	2,09E-03	1,99E-04	3,38E-04	6,17E-05	3,90E-02	0	0	6,12E-05	7,50E-06	1,53E-05	-1,31E-04
	TOTAL	kg CO₂ eq.	7,23E+00	4,21E-01	4,28E-01	1,30E-01	7,28E+01	0	0	1,25E-01	2,75E+00	2,15E-01	-2,57E+00
Acidification (AP)	mol H ⁺ eq.		2,56E-02	1,75E-03	1,91E-03	5,41E-04	3,50E-01	0	0	5,19E-04	3,56E-04	1,45E-04	-8,64E-03
Eutrophication - freshwater (EP-freshwater)	kg P eq.		1,07E-04	3,42E-06	6,74E-06	1,06E-06	9,19E-04	0	0	1,01E-06	3,42E-07	3,05E-07	-2,94E-05
Eutrophication - marine (EP-marine)	kg N eq.		4,50E-03	6,56E-04	6,54E-04	2,03E-04	1,14E-01	0	0	1,96E-04	1,70E-04	9,53E-05	-1,35E-03
Eutrophication terrestrial (EP)	mol N eq.		4,95E-02	7,06E-03	7,40E-03	2,19E-03	1,24E+00	0	0	2,11E-03	1,84E-03	5,71E-04	-1,59E-02
Ozone depletion layer (ODP)	kg CFC-11 eq.		7,63E-08	9,25E-09	9,15E-09	2,87E-09	1,56E-06	0	0	2,74E-09	7,02E-10	4,67E-10	-5,72E-08
Photochemical ozone formation (POCP)	kg NMVOC eq.		2,53E-02	2,65E-03	2,58E-03	8,22E-04	4,50E-01	0	0	7,59E-04	4,57E-04	2,47E-04	-8,40E-03
Depletion of abiotic resources (ADP) - Minerals and metals ²	kg Sb eq.		2,86E-05	1,14E-06	2,23E-06	3,54E-07	2,96E-04	0	0	4,05E-07	5,53E-08	4,21E-08	-2,43E-05
Depletion of abiotic resources (ADP) - Fossil fuels ²	MJ, net calorific value		2,41E+02	6,19E+00	6,02E+00	1,92E+00	1,26E+03	0	0	1,79E+00	2,54E-01	4,34E-01	-7,12E+01
Water use [WDP] ²	m ³ eq.		5,07E+00	2,96E-02	4,82E-02	9,17E-03	3,79E+01	0	0	7,29E-03	4,07E-03	1,82E-02	-1,65E+00

² The results of this environmental impact indicator shall be used with care as the uncertainties on these results are high or as there is limited experienced with the indicator.

ADDITIONAL ENVIRONMENTAL IMPACT INDICATORS

INDICATOR	UNIT	A1	A2	A3	A4	A5	B1-B7	C1	C2	C3	C4	D
Particulate Matter (PM) emissions	Disease incidence	2,55E-07	4,33E-08	3,60E-08	1,34E-08	5,97E-06	0	0	1,02E-08	1,59E-09	3,06E-09	-5,72E-08
Ionizing radiation (IRP), human health ¹	kBq U235 eq.	1,44E-01	2,98E-03	4,04E-03	9,23E-04	7,53E-01	0	0	8,96E-04	1,13E-04	2,39E-04	-2,79E-02
Eco-toxicity (freshwater) ² (ETP-fw)	CTUe	1,17E+01	2,98E+00	2,42E+00	9,22E-01	5,58E+02	0	0	8,82E-01	5,42E-01	3,24E-01	-3,45E+00
Human toxicity, cancer effects ² (HTP-c)	CTUh	1,70E-09	1,83E-10	5,08E-10	5,68E-11	3,76E-08	0	0	5,72E-11	9,57E-11	1,19E-11	1,08E-09
Human toxicity, non-cancer effects ² (HTP-nc)	CTUh	3,65E-08	4,44E-09	4,69E-09	1,38E-09	7,02E-07	0	0	1,26E-09	4,17E-09	4,65E-10	-2,41E-08
Land use related impacts/Soil quality ²	-	1,64E+01	6,28E+00	1,43E+01	1,95E+00	1,04E+03	0	0	1,06E+00	6,95E-02	9,80E-01	-5,83E-01

¹ This impact category deals mainly with the eventual impact of low dose ionizing radiation on human health of the nuclear fuel cycle. It does not consider effects due to possible nuclear accidents, occupational exposure nor due to radioactive waste disposal in underground facilities. Potential ionizing radiation from the soil, from radon and from some construction materials is also not measured by this indicator.

² The results of this environmental impact indicator shall be used with care as the uncertainties on these results are high or as there is limited experienced with the indicator.

PARAMETERS DESCRIBING RESOURCE USE

INDICATOR	UNIT		A1	A2	A3	A4	A5	B1-B7	C1	C2	C3	C4	D
Use of primary energy resources - Renewable	Used as energy carrier	MJ, net calorific value	2,98E+00	7,03E-02	1,15E-01	2,18E-02	1,80E+01	0	0	2,10E-02	3,88E-03	6,21E-03	-2,70E+00
	Used as raw material	MJ, net calorific value	3,07E+00	2,03E-02	1,93E+00	6,30E-03	1,12E+01	0	0	6,77E-03	2,07E-03	1,80E-03	-1,24E+00
	TOTAL	MJ, net calorific value	6,04E+00	9,06E-02	2,05E+00	2,81E-02	2,92E+01	0	0	2,77E-02	5,95E-03	8,02E-03	-3,10E+00
Use of primary energy resources - Non renewable	Used as energy carrier	MJ, net calorific value	5,34E+01	6,58E+00	6,41E+00	2,04E+00	1,23E+03	0	0	1,90E+00	2,76E-01	4,62E-01	-1,08E+02
	Used as raw material	MJ, net calorific value	2,05E+02	0	0	0	1,13E+02	0	0	0	0	0	0
	TOTAL	MJ, net calorific value	2,59E+02	6,58E+00	6,41E+00	2,04E+00	1,34E+03	0	0	1,90E+00	2,76E-01	4,62E-01	-1,08E+02
Use of secondary material	kg		0	0	0	0	0	0	0	0	0	0	0
Use of renewable secondary fuels	MJ, net calorific value		0	0	0	0	0	0	0	0	0	0	0
Use of non-renewable secondary fuels	MJ, net calorific value		0	0	0	0	0	0	0	0	0	0	0
Net use of fresh water	m ³		6,94E-02	9,07E-04	1,43E-03	2,81E-04	9,27E-01	0	0	2,39E-04	2,32E-04	4,37E-04	-2,67E-02

OTHER ENVIRONMENTAL INFORMATION DESCRIBING WASTE CATEGORIES

INDICATOR	UNIT	A1	A2	A3	A4	A5	B1-B7	C1	C2	C3	C4	D
Hazardous waste disposed	kg	1,91E-03	1,72E-04	4,53E-04	5,34E-05	3,80E-02	0	0	4,43E-05	2,04E-02	1,80E-05	6,85E-03
Non-hazardous waste disposed	kg	2,36E-01	5,42E-01	2,98E-01	1,68E-01	1,02E+03	0	0	8,73E-02	2,59E-02	1,70E+00	3,43E-02
Radioactive waste disposed	kg	1,14E-04	1,89E-06	2,74E-06	5,85E-07	4,89E-04	0	0	5,81E-07	7,36E-08	1,46E-07	-2,43E-05

ENVIRONMENTAL INFORMATION DESCRIBING OUTPUT FLOWS

INDICATOR	UNIT	A1	A2	A3	A4	A5	B1-B7	C1	C2	C3	C4	D
Components for re-use	kg	0	0	0	0	0	0	0	0	0	0	0
Materials for recycling	kg	0	0	2,11E-01	0	4,52E-02	0	0	0	8,98E-01	0	0
Materials for energy recovery	kg	0	0	0	0	0	0	0	0	0	0	0
Exported electricity	MJ	0	0	0	0	2,41E-01	0	0	0	6,21E+00	0	0
Exported thermal energy	MJ	0	0	0	0	4,82E-01	0	0	0	1,24E+01	0	0

BIOGENIC CARBON CONTENT

INDICATOR	UNIT	TOTAL
Biogenic carbon content	kg C	2,66E-02

CENTRALTUBI GAS DE140 S5 SDR11

CORE ENVIRONMENTAL IMPACT INDICATORS

INDICATOR	UNIT		A1	A2	A3	A4	A5	B1-B7	C1	C2	C3	C4	D
Global Warming Potential (GWP)	Fossil	kg CO ₂ eq.	1,17E+01	6,80E-01	6,91E-01	2,23E-01	7,92E+01	0	0	1,97E-01	4,47E+00	3,49E-01	-4,12E+00
	Biogenic	kg CO ₂ eq.	1,44E-02	2,00E-04	3,70E-04	6,57E-05	5,76E-02	0	0	5,71E-05	3,09E-05	1,75E-04	1,40E-02
	LULUC	kg CO ₂ eq.	3,38E-03	3,22E-04	5,47E-04	1,06E-04	4,25E-02	0	0	9,63E-05	1,22E-05	2,49E-05	-1,92E-04
	TOTAL	kg CO₂ eq.	1,17E+01	6,80E-01	6,92E-01	2,23E-01	7,93E+01	0	0	1,97E-01	4,47E+00	3,50E-01	-4,10E+00
Acidification (AP)	mol H ⁺ eq.		4,14E-02	2,82E-03	3,09E-03	9,27E-04	3,82E-01	0	0	8,15E-04	5,78E-04	2,36E-04	-1,35E-02
Eutrophication - freshwater (EP-freshwater)	kg P eq.		1,74E-04	5,53E-06	1,09E-05	1,82E-06	1,01E-03	0	0	1,59E-06	5,55E-07	4,97E-07	-4,30E-05
Eutrophication - marine (EP-marine)	kg N eq.		7,28E-03	1,06E-03	1,06E-03	3,49E-04	1,24E-01	0	0	3,08E-04	2,76E-04	1,55E-04	-2,12E-03
Eutrophication terrestrial (EP)	mol N eq.		8,01E-02	1,14E-02	1,20E-02	3,75E-03	1,35E+00	0	0	3,32E-03	2,99E-03	9,29E-04	-2,49E-02
Ozone depletion layer (ODP)	kg CFC-11 eq.		1,24E-07	1,50E-08	1,48E-08	4,91E-09	1,70E-06	0	0	4,31E-09	1,14E-09	7,60E-10	-9,16E-08
Photochemical ozone formation (POCP)	kg NMVOC eq.		4,09E-02	4,29E-03	4,18E-03	1,41E-03	4,90E-01	0	0	1,19E-03	7,43E-04	4,01E-04	-1,32E-02
Depletion of abiotic resources (ADP) - Minerals and metals ²	kg Sb eq.		4,62E-05	1,85E-06	3,61E-06	6,06E-07	3,28E-04	0	0	6,37E-07	8,99E-08	6,85E-08	-3,50E-05
Depletion of abiotic resources (ADP) - Fossil fuels ²	MJ, net calorific value		3,89E+02	1,00E+01	9,74E+00	3,29E+00	1,38E+03	0	0	2,81E+00	4,12E-01	7,05E-01	-1,15E+02
Water use [WDP] ²	m ³ eq.		8,19E+00	4,78E-02	7,79E-02	1,57E-02	4,16E+01	0	0	1,15E-02	6,58E-03	2,96E-02	-2,68E+00

² The results of this environmental impact indicator shall be used with care as the uncertainties on these results are high or as there is limited experienced with the indicator.

ADDITIONAL ENVIRONMENTAL IMPACT INDICATORS

INDICATOR	UNIT	A1	A2	A3	A4	A5	B1-B7	C1	C2	C3	C4	D
Particulate Matter (PM) emissions	Disease incidence	4,13E-07	7,00E-08	5,83E-08	2,30E-08	6,51E-06	0	0	1,61E-08	2,59E-09	4,97E-09	-8,69E-08
Ionizing radiation (IRP), human health ¹	kBq U235 eq.	2,33E-01	4,82E-03	6,54E-03	1,58E-03	8,32E-01	0	0	1,41E-03	1,83E-04	3,88E-04	-4,63E-02
Eco-toxicity (freshwater) ² (ETP-fw)	CTUe	1,89E+01	4,81E+00	3,92E+00	1,58E+00	6,05E+02	0	0	1,39E+00	8,76E-01	5,26E-01	-5,12E+00
Human toxicity, cancer effects ² (HTP-c)	CTUh	2,76E-09	2,96E-10	8,21E-10	9,73E-11	4,11E-08	0	0	9,00E-11	1,56E-10	1,93E-11	1,06E-09
Human toxicity, non-cancer effects ² (HTP-nc)	CTUh	5,90E-08	7,19E-09	7,58E-09	2,36E-09	7,69E-07	0	0	1,98E-09	6,78E-09	7,56E-10	-3,52E-08
Land use related impacts/Soil quality ²	-	2,75E+01	1,02E+01	2,31E+01	3,34E+00	1,14E+03	0	0	1,67E+00	1,13E-01	1,59E+00	-6,36E-01

¹ This impact category deals mainly with the eventual impact of low dose ionizing radiation on human health of the nuclear fuel cycle. It does not consider effects due to possible nuclear accidents, occupational exposure nor due to radioactive waste disposal in underground facilities. Potential ionizing radiation from the soil, from radon and from some construction materials is also not measured by this indicator.

² The results of this environmental impact indicator shall be used with care as the uncertainties on these results are high or as there is limited experienced with the indicator.

PARAMETERS DESCRIBING RESOURCE USE

INDICATOR	UNIT		A1	A2	A3	A4	A5	B1-B7	C1	C2	C3	C4	D
Use of primary energy resources - Renewable	Used as energy carrier	MJ, net calorific value	4,81E+00	1,14E-01	1,86E-01	3,73E-02	1,98E+01	0	0	3,30E-02	6,30E-03	1,01E-02	-4,34E+00
	Used as raw material	MJ, net calorific value	5,15E+00	3,29E-02	3,12E+00	1,08E-02	1,22E+01	0	0	1,06E-02	3,36E-03	2,93E-03	-1,92E+00
	TOTAL	MJ, net calorific value	9,96E+00	1,47E-01	3,31E+00	4,81E-02	3,21E+01	0	0	4,36E-02	9,66E-03	1,30E-02	-4,99E+00
Use of primary energy resources - Non renewable	Used as energy carrier	MJ, net calorific value	8,63E+01	1,06E+01	1,04E+01	3,49E+00	1,34E+03	0	0	9,59E+00	1,45E+00	2,43E+00	-5,19E+02
	Used as raw material	MJ, net calorific value	3,32E+02	0	0	0	1,28E+02	0	0	0	0	0	0
	TOTAL	MJ, net calorific value	4,18E+02	1,06E+01	1,04E+01	3,49E+00	1,47E+03	0	0	2,99E+00	4,49E-01	7,50E-01	-1,71E+02
Use of secondary material	kg		0	0	0	0	0	0	0	0	0	0	0
Use of renewable secondary fuels	MJ, net calorific value		0	0	0	0	0	0	0	0	0	0	0
Use of non-renewable secondary fuels	MJ, net calorific value		0	0	0	0	0	0	0	0	0	0	0
Net use of fresh water	m ³		1,12E-01	1,47E-03	2,31E-03	4,82E-04	1,01E+00	0	0	3,75E-04	3,73E-04	7,11E-04	-4,30E-02

OTHER ENVIRONMENTAL INFORMATION DESCRIBING WASTE CATEGORIES

INDICATOR	UNIT	A1	A2	A3	A4	A5	B1-B7	C1	C2	C3	C4	D
Hazardous waste disposed	kg	3,09E-03	2,79E-04	7,33E-04	9,16E-05	4,16E-02	0	0	6,96E-05	3,31E-02	2,94E-05	1,12E-02
Non-hazardous waste disposed	kg	3,82E-01	8,77E-01	4,81E-01	2,88E-01	1,11E+03	0	0	1,37E-01	4,20E-02	2,76E+00	8,20E-02
Radioactive waste disposed	kg	1,85E-04	3,05E-06	4,43E-06	1,00E-06	5,43E-04	0	0	9,13E-07	1,19E-07	2,37E-07	-4,04E-05

ENVIRONMENTAL INFORMATION DESCRIBING OUTPUT FLOWS

INDICATOR	UNIT	A1	A2	A3	A4	A5	B1-B7	C1	C2	C3	C4	D
Components for re-use	kg	0	0	0	0	0	0	0	0	0	0	0
Materials for recycling	kg	0	0	3,41E-01	0	7,61E-02	0	0	0	1,39E+00	0	0
Materials for energy recovery	kg	0	0	0	0	0,00E+00	0	0	0	0	0	0
Exported electricity	MJ	0	0	0	0	4,00E-01	0	0	0	1,01E+01	0	0
Exported thermal energy	MJ	0	0	0	0	8,00E-01	0	0	0	2,02E+01	0	0

BIOGENIC CARBON CONTENT

INDICATOR	UNIT	TOTAL
Biogenic carbon content	kg C	4,59E-02

CENTRALTUBI GAS DE160 S5 SDR11

CORE ENVIRONMENTAL IMPACT INDICATORS

INDICATOR	UNIT		A1	A2	A3	A4	A5	B1-B7	C1	C2	C3	C4	D
Global Warming Potential (GWP)	Fossil	kg CO ₂ eq.	1,53E+01	8,92E-01	9,08E-01	2,75E-01	8,39E+01	0	0	2,62E-01	5,90E+00	4,61E-01	-5,46E+00
	Biogenic	kg CO ₂ eq.	1,89E-02	2,63E-04	4,86E-04	8,10E-05	6,50E-02	0	0	7,61E-05	4,08E-05	2,31E-04	1,84E-02
	LULUC	kg CO ₂ eq.	4,45E-03	4,22E-04	7,18E-04	1,30E-04	4,52E-02	0	0	1,28E-04	1,61E-05	3,28E-05	-2,61E-04
	TOTAL	kg CO₂ eq.	1,53E+01	8,93E-01	9,09E-01	2,75E-01	8,40E+01	0	0	2,63E-01	5,90E+00	4,61E-01	-5,44E+00
Acidification (AP)	mol H ⁺ eq.		5,44E-02	3,70E-03	4,06E-03	1,14E-03	4,04E-01	0	0	1,09E-03	7,62E-04	3,11E-04	-1,80E-02
Eutrophication - freshwater (EP-freshwater)	kg P eq.		2,28E-04	7,26E-06	1,43E-05	2,24E-06	1,08E-03	0	0	2,11E-06	7,32E-07	6,55E-07	-5,86E-05
Eutrophication - marine (EP-marine)	kg N eq.		9,55E-03	1,39E-03	1,39E-03	4,30E-04	1,31E-01	0	0	4,11E-04	3,64E-04	2,04E-04	-2,83E-03
Eutrophication terrestrial (EP)	mol N eq.		1,05E-01	1,50E-02	1,57E-02	4,62E-03	1,43E+00	0	0	4,42E-03	3,95E-03	1,22E-03	-3,32E-02
Ozone depletion layer (ODP)	kg CFC-11 eq.		1,63E-07	1,96E-08	1,94E-08	6,05E-09	1,79E-06	0	0	5,74E-09	1,50E-09	1,00E-09	-1,22E-07
Photochemical ozone formation (POCP)	kg NMVOC eq.		5,37E-02	5,63E-03	5,48E-03	1,74E-03	5,19E-01	0	0	1,59E-03	9,79E-04	5,29E-04	-1,76E-02
Depletion of abiotic resources (ADP) - Minerals and metals ²	kg Sb eq.		6,06E-05	2,42E-06	4,73E-06	7,47E-07	3,56E-04	0	0	8,48E-07	1,18E-07	9,03E-08	-4,76E-05
Depletion of abiotic resources (ADP) - Fossil fuels ²	MJ, net calorific value		5,11E+02	1,31E+01	1,28E+01	4,05E+00	1,46E+03	0	0	3,74E+00	5,43E-01	9,30E-01	-1,52E+02
Water use [WDP] ²	m ³ eq.		1,07E+01	6,27E-02	1,02E-01	1,94E-02	4,42E+01	0	0	1,53E-02	8,67E-03	3,91E-02	-3,53E+00

² The results of this environmental impact indicator shall be used with care as the uncertainties on these results are high or as there is limited experienced with the indicator.

ADDITIONAL ENVIRONMENTAL IMPACT INDICATORS

INDICATOR	UNIT	A1	A2	A3	A4	A5	B1-B7	C1	C2	C3	C4	D
Particulate Matter (PM) emissions	Disease incidence	5,42E-07	9,19E-08	7,65E-08	2,84E-08	6,89E-06	0	0	2,14E-08	3,42E-09	6,56E-09	-1,17E-07
Ionizing radiation (IRP), human health ¹	kBq U235 eq.	3,06E-01	6,32E-03	8,58E-03	1,95E-03	8,97E-01	0	0	1,88E-03	2,42E-04	5,12E-04	-6,07E-02
Eco-toxicity (freshwater) ² (ETP-fw)	CTUe	2,48E+01	6,31E+00	5,14E+00	1,95E+00	6,39E+02	0	0	1,85E+00	1,15E+00	6,94E-01	-6,91E+00
Human toxicity, cancer effects ² (HTP-c)	CTUh	3,63E-09	3,89E-10	1,08E-09	1,20E-10	4,47E-08	0	0	1,20E-10	2,05E-10	2,55E-11	1,69E-09
Human toxicity, non-cancer effects ² (HTP-nc)	CTUh	7,74E-08	9,43E-09	9,95E-09	2,91E-09	8,24E-07	0	0	2,64E-09	8,94E-09	9,97E-10	-4,77E-08
Land use related impacts/Soil quality ²	-	3,68E+01	1,33E+01	3,04E+01	4,12E+00	1,21E+03	0	0	2,23E+00	1,49E-01	2,10E+00	-9,60E-01

¹ This impact category deals mainly with the eventual impact of low dose ionizing radiation on human health of the nuclear fuel cycle. It does not consider effects due to possible nuclear accidents, occupational exposure nor due to radioactive waste disposal in underground facilities. Potential ionizing radiation from the soil, from radon and from some construction materials is also not measured by this indicator.

² The results of this environmental impact indicator shall be used with care as the uncertainties on these results are high or as there is limited experienced with the indicator.

PARAMETERS DESCRIBING RESOURCE USE

INDICATOR	UNIT		A1	A2	A3	A4	A5	B1-B7	C1	C2	C3	C4	D
Use of primary energy resources - Renewable	Used as energy carrier	MJ, net calorific value	6,32E+00	1,49E-01	2,44E-01	4,60E-02	2,13E+01	0	0	4,39E-02	8,30E-03	1,33E-02	-5,75E+00
	Used as raw material	MJ, net calorific value	6,87E+00	4,32E-02	4,10E+00	1,33E-02	1,31E+01	0	0	1,42E-02	4,43E-03	3,87E-03	-2,50E+00
	TOTAL	MJ, net calorific value	1,32E+01	1,92E-01	4,34E+00	5,93E-02	3,44E+01	0	0	5,81E-02	1,27E-02	1,72E-02	-6,60E+00
Use of primary energy resources - Non renewable	Used as energy carrier	MJ, net calorific value	1,13E+02	1,40E+01	1,36E+01	4,30E+00	1,41E+03	0	0	3,98E+00	5,92E-01	9,89E-01	-2,24E+02
	Used as raw material	MJ, net calorific value	4,35E+02	0	0	0	1,41E+02	0	0	0	0	0	0
	TOTAL	MJ, net calorific value	5,49E+02	1,40E+01	1,36E+01	4,30E+00	1,55E+03	0	0	3,98E+00	5,92E-01	9,89E-01	-2,24E+02
Use of secondary material	kg		0	0	0	0	0	0	0	0	0	0	0
Use of renewable secondary fuels	MJ, net calorific value		0	0	0	0	0	0	0	0	0	0	0
Use of non-renewable secondary fuels	MJ, net calorific value		0	0	0	0	0	0	0	0	0	0	0
Net use of fresh water	m ³		1,47E-01	1,93E-03	3,03E-03	5,94E-04	1,08E+00	0	0	5,00E-04	4,92E-04	9,37E-04	-5,68E-02

OTHER ENVIRONMENTAL INFORMATION DESCRIBING WASTE CATEGORIES

INDICATOR	UNIT	A1	A2	A3	A4	A5	B1-B7	C1	C2	C3	C4	D
Hazardous waste disposed	kg	4,06E-03	3,66E-04	9,62E-04	1,13E-04	4,54E-02	0	0	9,27E-05	4,37E-02	3,87E-05	1,47E-02
Non-hazardous waste disposed	kg	5,02E-01	1,15E+00	6,32E-01	3,55E-01	1,18E+03	0	0	1,83E-01	5,53E-02	3,63E+00	9,72E-02
Radioactive waste disposed	kg	2,42E-04	4,01E-06	5,81E-06	1,24E-06	5,89E-04	0	0	1,22E-06	1,57E-07	3,12E-07	-5,29E-05

ENVIRONMENTAL INFORMATION DESCRIBING OUTPUT FLOWS

INDICATOR	UNIT	A1	A2	A3	A4	A5	B1-B7	C1	C2	C3	C4	D
Components for re-use	kg	0	0	0	0	0	0	0	0	0	0	0
Materials for recycling	kg	0	0	4,48E-01	0	1,02E-01	0	0	0	1,86E+00	0	0
Materials for energy recovery	kg	0	0	0	0	0	0	0	0	0	0	0
Exported electricity	MJ	0	0	0	0	5,31E-01	0	0	0	1,33E+01	0	0
Exported thermal energy	MJ	0	0	0	0	1,06E+00	0	0	0	2,66E+01	0	0

BIOGENIC CARBON CONTENT

INDICATOR	UNIT	TOTAL
Biogenic carbon content	kg C	6,22E-02

CENTRALTUBI GAS DE200 S5 SDR11

CORE ENVIRONMENTAL IMPACT INDICATORS

INDICATOR	UNIT		A1	A2	A3	A4	A5	B1-B7	C1	C2	C3	C4	D
Global Warming Potential (GWP)	Fossil	kg CO ₂ eq.	2,39E+01	1,39E+00	1,41E+00	4,53E-01	9,37E+01	0	0	4,09E-01	9,29E+00	7,25E-01	-8,54E+00
	Biogenic	kg CO ₂ eq.	2,94E-02	4,09E-04	7,57E-04	1,33E-04	7,71E-02	0	0	1,19E-04	6,42E-05	3,64E-04	2,90E-02
	LULUC	kg CO ₂ eq.	6,90E-03	6,59E-04	1,12E-03	2,14E-04	5,06E-02	0	0	2,00E-04	2,53E-05	5,16E-05	-3,94E-04
	TOTAL	kg CO₂ eq.	2,39E+01	1,39E+00	1,42E+00	4,53E-01	9,39E+01	0	0	4,10E-01	9,29E+00	7,25E-01	-8,51E+00
Acidification (AP)	mol H+ eq.		8,48E-02	5,77E-03	6,32E-03	1,88E-03	4,52E-01	0	0	1,69E-03	1,20E-03	4,89E-04	-2,77E-02
Eutrophication - freshwater (EP-freshwater)	kg P eq.		3,55E-04	1,13E-05	2,23E-05	3,68E-06	1,23E-03	0	0	3,30E-06	1,15E-06	1,03E-06	-8,87E-05
Eutrophication - marine (EP-marine)	kg N eq.		1,49E-02	2,17E-03	2,16E-03	7,07E-04	1,46E-01	0	0	6,41E-04	5,74E-04	3,21E-04	-4,39E-03
Eutrophication terrestrial (EP)	mol N eq.		1,64E-01	2,34E-02	2,45E-02	7,60E-03	1,59E+00	0	0	6,90E-03	6,21E-03	1,93E-03	-5,15E-02
Ozone depletion layer (ODP)	kg CFC-11 eq.		2,52E-07	3,06E-08	3,03E-08	9,96E-09	2,00E-06	0	0	8,96E-09	2,37E-09	1,58E-09	-1,89E-07
Photochemical ozone formation (POCP)	kg NMVOC eq.		8,37E-02	8,77E-03	8,54E-03	2,85E-03	5,78E-01	0	0	2,48E-03	1,54E-03	8,32E-04	-2,73E-02
Depletion of abiotic resources (ADP) - Minerals and metals ²	kg Sb eq.		9,44E-05	3,78E-06	7,38E-06	1,23E-06	4,09E-04	0	0	1,32E-06	1,87E-07	1,42E-07	-7,00E-05
Depletion of abiotic resources (ADP) - Fossil fuels ²	MJ, net calorific value		7,96E+02	2,05E+01	1,99E+01	6,66E+00	1,64E+03	0	0	5,84E+00	8,56E-01	1,46E+00	-2,39E+02
Water use [WDP] ²	m ³ eq.		1,68E+01	9,78E-02	1,59E-01	3,18E-02	4,97E+01	0	0	2,38E-02	1,37E-02	6,15E-02	-5,55E+00

² The results of this environmental impact indicator shall be used with care as the uncertainties on these results are high or as there is limited experienced with the indicator.

ADDITIONAL ENVIRONMENTAL IMPACT INDICATORS

INDICATOR	UNIT	A1	A2	A3	A4	A5	B1-B7	C1	C2	C3	C4	D
Particulate Matter (PM) emissions	Disease incidence	8,43E-07	1,43E-07	1,19E-07	4,66E-08	7,68E-06	0	0	3,34E-08	5,38E-09	1,03E-08	-1,80E-07
Ionizing radiation (IRP), human health ¹	kBq U235 eq.	4,77E-01	9,85E-03	1,34E-02	3,21E-03	1,04E+00	0	0	2,93E-03	3,81E-04	8,06E-04	-9,57E-02
Eco-toxicity (freshwater) ² (ETP-fw)	CTUe	3,87E+01	9,84E+00	8,02E+00	3,20E+00	7,09E+02	0	0	2,88E+00	1,83E+00	1,09E+00	-1,04E+01
Human toxicity, cancer effects ² (HTP-c)	CTUh	5,64E-09	6,06E-10	1,68E-09	1,97E-10	5,10E-08	0	0	1,87E-10	3,23E-10	4,01E-11	2,30E-09
Human toxicity, non-cancer effects ² (HTP-nc)	CTUh	1,21E-07	1,47E-08	1,55E-08	4,79E-09	9,31E-07	0	0	4,11E-09	1,41E-08	1,57E-09	-7,04E-08
Land use related impacts/Soil quality ²	-	5,46E+01	2,08E+01	4,73E+01	6,77E+00	1,35E+03	0	0	3,48E+00	2,35E-01	3,30E+00	-1,27E+00

¹ This impact category deals mainly with the eventual impact of low dose ionizing radiation on human health of the nuclear fuel cycle. It does not consider effects due to possible nuclear accidents, occupational exposure nor due to radioactive waste disposal in underground facilities. Potential ionizing radiation from the soil, from radon and from some construction materials is also not measured by this indicator.

² The results of this environmental impact indicator shall be used with care as the uncertainties on these results are high or as there is limited experience with the indicator.

PARAMETERS DESCRIBING RESOURCE USE

INDICATOR	UNIT		A1	A2	A3	A4	A5	B1-B7	C1	C2	C3	C4	D
Use of primary energy resources - Renewable	Used as energy carrier	MJ, net calorific value	9,85E+00	2,32E-01	3,80E-01	7,56E-02	2,46E+01	0	0	6,85E-02	1,31E-02	2,10E-02	-9,00E+00
	Used as raw material	MJ, net calorific value	1,02E+01	6,73E-02	6,39E+00	2,19E-02	1,48E+01	0	0	2,21E-02	6,98E-03	6,09E-03	-3,85E+00
	TOTAL	MJ, net calorific value	2,00E+01	3,00E-01	6,77E+00	9,75E-02	3,94E+01	0	0	9,06E-02	2,01E-02	2,70E-02	-1,03E+01
Use of primary energy resources - Non renewable	Used as energy carrier	MJ, net calorific value	1,77E+02	2,18E+01	2,12E+01	7,08E+00	1,57E+03	0	0	6,21E+00	9,32E-01	1,56E+00	-3,49E+02
	Used as raw material	MJ, net calorific value	6,79E+02	0	0	0	1,73E+02	0	0	0	0	0	0
	TOTAL	MJ, net calorific value	8,55E+02	2,18E+01	2,12E+01	7,08E+00	1,75E+03	0	0	6,21E+00	9,32E-01	1,56E+00	-3,49E+02
Use of secondary material	kg		0	0	0	0	0	0	0	0	0	0	0
Use of renewable secondary fuels	MJ, net calorific value		0	0	0	0	0	0	0	0	0	0	0
Use of non-renewable secondary fuels	MJ, net calorific value		0	0	0	0	0	0	0	0	0	0	0
Net use of fresh water	m ³		2,29E-01	3,00E-03	4,73E-03	9,77E-04	1,20E+00	0	0	7,80E-04	7,82E-04	1,47E-03	-8,91E-02

OTHER ENVIRONMENTAL INFORMATION DESCRIBING WASTE CATEGORIES

INDICATOR	UNIT	A1	A2	A3	A4	A5	B1-B7	C1	C2	C3	C4	D
Hazardous waste disposed	kg	6,31E-03	5,70E-04	1,50E-03	1,86E-04	5,22E-02	0	0	1,45E-04	6,88E-02	6,09E-05	2,32E-02
Non-hazardous waste disposed	kg	7,82E-01	1,79E+00	9,85E-01	5,84E-01	1,31E+03	0	0	2,85E-01	8,72E-02	5,72E+00	1,69E-01
Radioactive waste disposed	kg	3,78E-04	6,24E-06	9,06E-06	2,03E-06	6,90E-04	0	0	1,90E-06	2,48E-07	4,92E-07	-8,35E-05

ENVIRONMENTAL INFORMATION DESCRIBING OUTPUT FLOWS

INDICATOR	UNIT	A1	A2	A3	A4	A5	B1-B7	C1	C2	C3	C4	D
Components for re-use	kg	0	0	0	0	0	0	0	0	0	0	0
Materials for recycling	kg	0	0	6,98E-01	0	1,50E-01	0	0	0	2,89E+00	0	0
Materials for energy recovery	kg	0	0	0	0	0	0	0	0	0	0	0
Exported electricity	MJ	0	0	0	0	7,96E-01	0	0	0	2,10E+01	0	0
Exported thermal energy	MJ	0	0	0	0	1,59E+00	0	0	0	4,19E+01	0	0

BIOGENIC CARBON CONTENT

INDICATOR	UNIT	TOTAL
Biogenic carbon content	kg C	8,84E-02

CENTRALTUBI GAS DE280 S5 SDR11

CORE ENVIRONMENTAL IMPACT INDICATORS

INDICATOR	UNIT		A1	A2	A3	A4	A5	B1-B7	C1	C2	C3	C4	D
Global Warming Potential (GWP)	Fossil	kg CO ₂ eq.	4,66E+01	2,71E+00	2,76E+00	4,74E-01	1,31E+02	0	0	7,86E-01	1,83E+01	1,43E+00	-1,66E+01
	Biogenic	kg CO ₂ eq.	5,75E-02	7,99E-04	1,48E-03	1,40E-04	1,08E-01	0	0	2,28E-04	1,26E-04	7,15E-04	5,70E-02
	LULUC	kg CO ₂ eq.	1,35E-02	1,28E-03	2,18E-03	2,25E-04	7,08E-02	0	0	3,84E-04	4,97E-05	1,02E-04	-7,01E-04
	TOTAL	kg CO₂ eq.	4,66E+01	2,72E+00	2,76E+00	4,75E-01	1,31E+02	0	0	7,87E-01	1,83E+01	1,43E+00	-1,65E+01
Acidification (AP)	mol H ⁺ eq.		1,65E-01	1,13E-02	1,23E-02	1,97E-03	6,29E-01	0	0	3,25E-03	2,36E-03	9,62E-04	-5,24E-02
Eutrophication - freshwater (EP-freshwater)	kg P eq.		6,94E-04	2,21E-05	4,35E-05	3,86E-06	1,73E-03	0	0	6,33E-06	2,26E-06	2,03E-06	-1,59E-04
Eutrophication - marine (EP-marine)	kg N eq.		2,91E-02	4,24E-03	4,22E-03	7,40E-04	2,03E-01	0	0	1,23E-03	1,13E-03	6,32E-04	-8,38E-03
Eutrophication terrestrial (EP)	mol N eq.		3,20E-01	4,56E-02	4,78E-02	7,97E-03	2,21E+00	0	0	1,33E-02	1,22E-02	3,79E-03	-9,82E-02
Ozone depletion layer (ODP)	kg CFC-11 eq.		4,96E-07	5,97E-08	5,91E-08	1,04E-08	2,77E-06	0	0	1,72E-08	4,64E-09	3,10E-09	-3,69E-07
Photochemical ozone formation (POCP)	kg NMVOC eq.		1,63E-01	1,71E-02	1,67E-02	2,99E-03	8,04E-01	0	0	4,77E-03	3,03E-03	1,64E-03	-5,23E-02
Depletion of abiotic resources (ADP) - Minerals and metals ²	kg Sb eq.		1,84E-04	7,37E-06	1,44E-05	1,29E-06	5,79E-04	0	0	2,54E-06	3,67E-07	2,80E-07	-1,18E-04
Depletion of abiotic resources (ADP) - Fossil fuels ²	MJ, net calorific value		1,55E+03	3,99E+01	3,89E+01	6,98E+00	2,31E+03	0	0	1,12E+01	1,68E+00	2,88E+00	-4,67E+02
Water use [WDP] ²	m ³ eq.		3,27E+01	1,91E-01	3,11E-01	3,34E-02	7,06E+01	0	0	4,57E-02	2,68E-02	1,21E-01	-1,09E+01

² The results of this environmental impact indicator shall be used with care as the uncertainties on these results are high or as there is limited experienced with the indicator.

ADDITIONAL ENVIRONMENTAL IMPACT INDICATORS

INDICATOR	UNIT	A1	A2	A3	A4	A5	B1-B7	C1	C2	C3	C4	D
Particulate Matter (PM) emissions	Disease incidence	1,65E-06	2,80E-07	2,33E-07	4,89E-08	1,07E-05	0	0	6,42E-08	1,06E-08	2,03E-08	-3,37E-07
Ionizing radiation (IRP), human health ¹	kBq U235 eq.	9,31E-01	1,92E-02	2,61E-02	3,36E-03	1,52E+00	0	0	5,62E-03	7,47E-04	1,59E-03	-1,90E-01
Eco-toxicity (freshwater) ² (ETP-fw)	CTUe	7,56E+01	1,92E+01	1,56E+01	3,36E+00	9,77E+02	0	0	5,53E+00	3,57E+00	2,15E+00	-1,83E+01
Human toxicity, cancer effects ² (HTP-c)	CTUh	1,10E-08	1,18E-09	3,28E-09	2,07E-10	7,09E-08	0	0	3,59E-10	6,35E-10	7,88E-11	2,70E-09
Human toxicity, non-cancer effects ² (HTP-nc)	CTUh	2,35E-07	2,87E-08	3,03E-08	5,01E-09	1,30E-06	0	0	7,90E-09	2,77E-08	3,09E-09	-1,20E-07
Land use related impacts/Soil quality ²	-	1,11E+02	4,05E+01	9,23E+01	7,09E+00	1,90E+03	0	0	6,68E+00	4,61E-01	6,50E+00	-1,48E+00

¹ This impact category deals mainly with the eventual impact of low dose ionizing radiation on human health of the nuclear fuel cycle. It does not consider effects due to possible nuclear accidents, occupational exposure nor due to radioactive waste disposal in underground facilities. Potential ionizing radiation from the soil, from radon and from some construction materials is also not measured by this indicator.

² The results of this environmental impact indicator shall be used with care as the uncertainties on these results are high or as there is limited experienced with the indicator.

PARAMETERS DESCRIBING RESOURCE USE

INDICATOR	UNIT		A1	A2	A3	A4	A5	B1-B7	C1	C2	C3	C4	D
Use of primary energy resources - Renewable	Used as energy carrier	MJ, net calorific value	1,92E+01	4,54E-01	7,42E-01	7,92E-02	3,54E+01	0	0	1,32E-01	2,57E-02	4,12E-02	-1,75E+01
	Used as raw material	MJ, net calorific value	2,07E+01	1,31E-01	1,25E+01	2,29E-02	2,10E+01	0	0	4,25E-02	1,37E-02	1,20E-02	-7,36E+00
	TOTAL	MJ, net calorific value	3,99E+01	5,85E-01	1,32E+01	1,02E-01	5,64E+01	0	0	1,74E-01	3,94E-02	5,32E-02	-2,02E+01
Use of primary energy resources - Non renewable	Used as energy carrier	MJ, net calorific value	3,45E+02	4,24E+01	4,14E+01	7,42E+00	2,18E+03	0	0	1,19E+01	1,83E+00	3,06E+00	-6,77E+02
	Used as raw material	MJ, net calorific value	1,32E+03	0	0	0	2,72E+02	0	0	0	0	0	0
	TOTAL	MJ, net calorific value	1,67E+03	4,24E+01	4,14E+01	7,42E+00	2,45E+03	0	0	1,19E+01	1,83E+00	3,06E+00	-6,77E+02
Use of secondary material	kg		0	0	0	0	0	0	0	0	0	0	0
Use of renewable secondary fuels	MJ, net calorific value		0	0	0	0	0	0	0	0	0	0	0
Use of non-renewable secondary fuels	MJ, net calorific value		0	0	0	0	0	0	0	0	0	0	0
Net use of fresh water	m ³		4,48E-01	5,86E-03	9,23E-03	1,02E-03	1,70E+00	0	0	1,50E-03	1,51E-03	2,90E-03	-1,74E-01

OTHER ENVIRONMENTAL INFORMATION DESCRIBING WASTE CATEGORIES

INDICATOR	UNIT	A1	A2	A3	A4	A5	B1-B7	C1	C2	C3	C4	D
Hazardous waste disposed	kg	1,23E-02	1,11E-03	2,92E-03	1,94E-04	7,33E-02	0	0	2,78E-04	1,35E-01	1,20E-04	4,56E-02
Non-hazardous waste disposed	kg	1,53E+00	3,50E+00	1,92E+00	6,12E-01	1,83E+03	0	0	5,48E-01	1,71E-01	1,12E+01	4,07E-01
Radioactive waste disposed	kg	7,37E-04	1,22E-05	1,77E-05	2,13E-06	1,02E-03	0	0	3,65E-06	4,86E-07	9,67E-07	-1,66E-04

ENVIRONMENTAL INFORMATION DESCRIBING OUTPUT FLOWS

INDICATOR	UNIT	A1	A2	A3	A4	A5	B1-B7	C1	C2	C3	C4	D
Components for re-use	kg	0	0	0	0	0	0	0	0	0	0	0
Materials for recycling	kg	0	0	1,36E+00	0	3,07E-01	0	0	0	5,48E+00	0	0
Materials for energy recovery	kg	0	0	0	0	0	0	0	0	0	0	0
Exported electricity	MJ	0	0	0	0	1,60E+00	0	0	0	4,12E+01	0	0
Exported thermal energy	MJ	0	0	0	0	3,20E+00	0	0	0	8,24E+01	0	0

BIOGENIC CARBON CONTENT

INDICATOR	UNIT	TOTAL
Biogenic carbon content	kg C	1,86E-01

CENTRALTUBI GAS DE355 S5 SDR11

CORE ENVIRONMENTAL IMPACT INDICATORS

INDICATOR	UNIT		A1	A2	A3	A4	A5	B1-B7	C1	C2	C3	C4	D
Global Warming Potential (GWP)	Fossil	kg CO ₂ eq.	7,50E+01	4,37E+00	4,45E+00	6,55E-01	1,89E+02	0	0	1,30E+00	2,99E+01	2,33E+00	-2,72E+01
	Biogenic	kg CO ₂ eq.	9,27E-02	1,29E-03	2,38E-03	1,93E-04	1,70E-01	0	0	3,76E-04	2,07E-04	1,17E-03	9,32E-02
	LULUC	kg CO ₂ eq.	2,19E-02	2,07E-03	3,52E-03	3,10E-04	1,03E-01	0	0	6,34E-04	8,13E-05	1,66E-04	-1,16E-03
	TOTAL	kg CO₂ eq.	7,51E+01	4,37E+00	4,45E+00	6,55E-01	1,89E+02	0	0	1,30E+00	2,99E+01	2,34E+00	-2,71E+01
Acidification (AP)	mol H ⁺ eq.		2,66E-01	1,81E-02	1,99E-02	2,72E-03	9,09E-01	0	0	5,37E-03	3,86E-03	1,57E-03	-8,60E-02
Eutrophication - freshwater (EP-freshwater)	kg P eq.		1,12E-03	3,56E-05	7,01E-05	5,33E-06	2,57E-03	0	0	1,05E-05	3,71E-06	3,32E-06	-2,65E-04
Eutrophication - marine (EP-marine)	kg N eq.		4,68E-02	6,82E-03	6,81E-03	1,02E-03	2,93E-01	0	0	2,03E-03	1,85E-03	1,04E-03	-1,38E-02
Eutrophication terrestrial (EP)	mol N eq.		5,15E-01	7,34E-02	7,69E-02	1,10E-02	3,19E+00	0	0	2,19E-02	2,00E-02	6,20E-03	-1,62E-01
Ozone depletion layer (ODP)	kg CFC-11 eq.		8,09E-07	9,61E-08	9,52E-08	1,44E-08	3,99E-06	0	0	2,84E-08	7,59E-09	5,08E-09	-6,11E-07
Photochemical ozone formation (POCP)	kg NMVOC eq.		2,63E-01	2,76E-02	2,69E-02	4,13E-03	1,16E+00	0	0	7,87E-03	4,96E-03	2,68E-03	-8,63E-02
Depletion of abiotic resources (ADP) - Minerals and metals ²	kg Sb eq.		2,97E-04	1,19E-05	2,32E-05	1,78E-06	8,49E-04	0	0	4,19E-06	6,00E-07	4,58E-07	-1,91E-04
Depletion of abiotic resources (ADP) - Fossil fuels ²	MJ, net calorific value		2,50E+03	6,43E+01	6,27E+01	9,64E+00	3,36E+03	0	0	1,85E+01	2,75E+00	4,71E+00	-7,66E+02
Water use [WDP] ²	m ³ eq.		5,26E+01	3,07E-01	5,01E-01	4,61E-02	1,04E+02	0	0	7,55E-02	4,39E-02	1,98E-01	-1,78E+01

² The results of this environmental impact indicator shall be used with care as the uncertainties on these results are high or as there is limited experienced with the indicator.

ADDITIONAL ENVIRONMENTAL IMPACT INDICATORS

INDICATOR	UNIT	A1	A2	A3	A4	A5	B1-B7	C1	C2	C3	C4	D
Particulate Matter (PM) emissions	Disease incidence	2,66E-06	4,50E-07	3,75E-07	6,75E-08	1,54E-05	0	0	1,06E-07	1,73E-08	3,32E-08	-5,60E-07
Ionizing radiation (IRP), human health ¹	kBq U235 eq.	1,50E+00	3,10E-02	4,21E-02	4,64E-03	2,29E+00	0	0	9,28E-03	1,22E-03	2,59E-03	-3,10E-01
Eco-toxicity (freshwater) ² (ETP-fw)	CTUe	1,22E+02	3,09E+01	2,52E+01	4,64E+00	1,40E+03	0	0	9,13E+00	5,84E+00	3,52E+00	-2,97E+01
Human toxicity, cancer effects ² (HTP-c)	CTUh	1,78E-08	1,90E-09	5,28E-09	2,85E-10	1,06E-07	0	0	5,93E-10	1,04E-09	1,29E-10	5,68E-09
Human toxicity, non-cancer effects ² (HTP-nc)	CTUh	3,79E-07	4,62E-08	4,88E-08	6,93E-09	1,89E-06	0	0	1,30E-08	4,53E-08	5,05E-09	-1,95E-07
Land use related impacts/Soil quality ²	-	1,92E+02	6,53E+01	1,49E+02	9,79E+00	2,77E+03	0	0	1,10E+01	7,54E-01	1,06E+01	-2,74E+00

¹ This impact category deals mainly with the eventual impact of low dose ionizing radiation on human health of the nuclear fuel cycle. It does not consider effects due to possible nuclear accidents, occupational exposure nor due to radioactive waste disposal in underground facilities. Potential ionizing radiation from the soil, from radon and from some construction materials is also not measured by this indicator.

² The results of this environmental impact indicator shall be used with care as the uncertainties on these results are high or as there is limited experience with the indicator.

PARAMETERS DESCRIBING RESOURCE USE

INDICATOR	UNIT		A1	A2	A3	A4	A5	B1-B7	C1	C2	C3	C4	D
Use of primary energy resources - Renewable	Used as energy carrier	MJ, net calorific value	3,09E+01	7,31E-01	1,20E+00	1,09E-01	5,31E+01	0	0	2,17E-01	4,20E-02	6,75E-02	-2,88E+01
	Used as raw material	MJ, net calorific value	3,58E+01	2,11E-01	2,01E+01	3,17E-02	3,09E+01	0	0	7,01E-02	2,24E-02	1,96E-02	-1,20E+01
	TOTAL	MJ, net calorific value	6,67E+01	9,42E-01	2,13E+01	1,41E-01	8,41E+01	0	0	2,87E-01	6,45E-02	8,71E-02	-3,30E+01
Use of primary energy resources - Non renewable	Used as energy carrier	MJ, net calorific value	5,55E+02	6,84E+01	6,67E+01	1,02E+01	3,14E+03	0	0	1,97E+01	3,00E+00	5,01E+00	-1,11E+03
	Used as raw material	MJ, net calorific value	2,13E+03	0	0	0	4,36E+02	0	0	0	0	0	0
	TOTAL	MJ, net calorific value	2,69E+03	6,84E+01	6,67E+01	1,02E+01	3,57E+03	0	0	1,97E+01	3,00E+00	5,01E+00	-1,11E+03
Use of secondary material	kg		0	0	0	0	0	0	0	0	0	0	0
Use of renewable secondary fuels	MJ, net calorific value		0	0	0	0	0	0	0	0	0	0	0
Use of non-renewable secondary fuels	MJ, net calorific value		0	0	0	0	0	0	0	0	0	0	0
Net use of fresh water	m ³		7,20E-01	9,43E-03	1,49E-02	1,41E-03	2,49E+00	0	0	2,47E-03	2,48E-03	4,75E-03	-2,85E-01

OTHER ENVIRONMENTAL INFORMATION DESCRIBING WASTE CATEGORIES

INDICATOR	UNIT	A1	A2	A3	A4	A5	B1-B7	C1	C2	C3	C4	D
Hazardous waste disposed	kg	2,00E-02	1,79E-03	4,71E-03	2,69E-04	1,10E-01	0	0	4,58E-04	2,21E-01	1,96E-04	7,47E-02
Non-hazardous waste disposed	kg	2,47E+00	5,64E+00	3,10E+00	8,46E-01	2,64E+03	0	0	9,05E-01	2,80E-01	1,84E+01	6,26E-01
Radioactive waste disposed	kg	1,19E-03	1,96E-05	2,85E-05	2,94E-06	1,56E-03	0	0	6,02E-06	7,95E-07	1,58E-06	-2,71E-04

ENVIRONMENTAL INFORMATION DESCRIBING OUTPUT FLOWS

INDICATOR	UNIT	A1	A2	A3	A4	A5	B1-B7	C1	C2	C3	C4	D
Components for re-use	kg	0	0	0	0	0	0	0	0	0	0	0
Materials for recycling	kg	0	0	2,20E+00	0	5,33E-01	0	0	0	9,08E+00	0	0
Materials for energy recovery	kg	0	0	0	0	0	0	0	0	0	0	0
Exported electricity	MJ	0	0	0	0	2,71E+00	0	0	0	6,74E+01	0	0
Exported thermal energy	MJ	0	0	0	0	5,42E+00	0	0	0	1,35E+02	0	0

BIOGENIC CARBON CONTENT

INDICATOR	UNIT	TOTAL
Biogenic carbon content	kg C	3,41E-01

7. Calculation rules

Cut-off rules

According to PCR, inventory data that contributes less than 5% to the environmental impacts of each module may not be included in the life cycle.

Allocation rules

According to the PCR, since the process under consideration is characterised by different products, an allocation procedure was required. Where possible, the system was divided into sub-processes and the data collected per process. Where this has not been possible, the allocation between different products and co-products has been made on the basis of physical relationships, namely the mass (kg) of the products.

Environmental impacts

The environmental impacts considered, expressed per declared unit, and divided into the phases considered, are the following:

Global warming, kg CO₂ equivalent (GWP100);

Acidification potential, Accumulated Exceedance (AP), mol H⁺ equivalent;

Eutrophication potential, fraction of nutrients reaching freshwater end compartment (EP-freshwater), kg PO₄ equivalent;

Eutrophication potential, fraction of nutrients reaching marine end compartment (EP-marine), kg N equivalent;

Eutrophication potential, Accumulated Exceedance (EP-terrestrial), mol N equivalent;

Depletion potential of the stratospheric ozone layer (ODP), kg CFC 11 equivalent;

Formation potential of tropospheric ozone (POCP), kg NMVOC equivalent;

Abiotic depletion potential for non-fossil resources (ADP-minerals&metals), kg Sb equivalent;

Abiotic depletion for fossil resources potential (ADP-fossil), MJ net calorific value;

Water (user) deprivation potential, deprivation-weighted water consumption (WDP), m³ world equivalent deprived;

Potential incidence of disease due to PM emissions (PM), disease incidence;

Potential Human exposure efficiency relative to U235 (IRP); kBq U235 equivalent;

Potential Comparative Toxic Unit for ecosystems (ETP-fw), CTUe;

Potential Comparative Toxic Unit for humans (HTP-c), CTUh;

Potential Comparative Toxic Unit for humans (HTP-nc), CTUh;

Potential Soil quality index (SQP), dimensionless.

Resource use

The consumption of resources considered, expressed per declared unit and subdivided in the phases considered, are the following:

- Use of renewable primary energy resources used as energy carrier (MJ, net calorific value);
- Use of renewable primary energy resources used as raw materials (MJ, net calorific value);
- Total use of renewable primary energy resources (MJ, net calorific value);
- Use of non-renewable primary energy resources used as energy carrier (MJ, net calorific value);
- Use of non-renewable primary energy resources used as raw materials (MJ, net calorific value);
- Total use of non-renewable primary energy resources (MJ, net calorific value);
- Use of secondary material (kg);
- Use of renewable secondary fuels (MJ, net calorific value);
- Use of non-renewable secondary fuels (MJ, net calorific value);
- Use of net fresh water (m³).

Waste

The waste products concerned, expressed per declared unit and divided into the stages concerned, are as follows:

- Hazardous waste disposed (kg);
- Non-hazardous waste disposed (kg);
- Radioactive waste disposed (kg).

Data quality

For most of the processes that refer to the production of the object of study and its logistics, specific data collected from company accounting reports are used. The transport of raw materials is modelled from the means of transport used and the distance from the supplier, as well as the delivery of the product to the yard.

Generic data selected from the Ecoinvent database v.3.9 are used for the production of raw materials, fuels and electricity (www.ecoinvent.org).

The product installation scenario, as well as its end-of-life, have been modelled on the basis of specific data and the requirements of the reference standard.

The reference version of the characterization factors used is the “EF 3.1 normalization and weighting set”.

The LCA method applied is “Cut of by classification”. The calculation software used is SimaPro 9.5.

Residual energy mix was considered in the calculation, for the low voltage energy consumption the data set is: “Electricity, low voltage {IT}| market for electricity, low voltage | Cut-off, U - Residual mix 2022” with an emission factor of 0.6483 kgCO₂eq/kWh and for medium voltage energy consumption the data set is “Electricity, medium voltage {IT}| market for electricity, medium voltage | Cut-off, U - Residual mix 2022” with an emission factor of 0.6496 kgCO₂eq/kWh.

8. Scenarios and additional technical information

A4 – Transport to the building site

The 2022 logistic scenario referred to the product under study is depicted in the table below.

Mean of transport	Truck		Ship	
	Quantity in percentage	Average distance	Quantity in percentage	Average distance
CENTRALTUBI GAS DE20 S5	100,00%	1082,20 km	0,00%	0 km
CENTRALTUBI GAS DE32 S5	98,45%	484,93 km	1,55%	745,7 km
CENTRALTUBI GAS DE50 S5	99,55%	389,02 km	0,45%	829 km
CENTRALTUBI GAS DE75 S5	96,60%	380,71 km	3,40%	819 km
CENTRALTUBI GAS DE110 S5	100,00%	390,40 km	0,00%	0 km
CENTRALTUBI GAS DE140 S5	100,00%	413,20 km	0,00%	0 km
CENTRALTUBI GAS DE160 S5	100,00%	387,77 km	0,00%	0 km
CENTRALTUBI GAS DE200 S5	100,00%	409,84 km	0,00%	0 km
CENTRALTUBI GAS DE280 S5	100,00%	219,75 km	0,00%	0 km
CENTRALTUBI GAS DE355 S5	100,00%	188,00 km	0,00%	0 km

The truck is assumed to be Lorry > 32 metric ton, EURO 4 – Average load factor 15.96 tonnes, - Gross vehicle weight 29.96 tonnes.

The ship is assumed to be Container ship – Load capacity 43000 tonnes.

A5 – Installation in the trench

For Module A5 the following parameters have been taken into account.

		DE20 S5	DE32 S5	DE50 S5	DE75 S5	DE110 S5	DE140 S5	DE160 S5	DE200 S5	DE280 S8	DE355 S5	
Energy consumption of the excavated volume ^a [MJ/tonne excavated]		2.69										
Excavated mass, total [kg/m]		7,37E+02	7,68E+02	8,16E+02	8,85E+02	9,86E+02	1,08E+03	1,14E+03	1,27E+03	1,77E+03	2,56E+03	
Excavated mass transported to depot [kg/m]		7,37E+02	7,68E+02	8,16E+02	8,85E+02	9,86E+02	1,08E+03	1,14E+03	1,27E+03	1,77E+03	2,56E+03	
Transport distance from the construction site to depot [km]		200										
Refilling mass [kg/m]		6,21E+02	6,46E+02	6,85E+02	7,39E+02	8,16E+02	8,83E+02	9,27E+02	1,02E+03	1,39E+03	1,99E+03	
Ancillary materials for installation [kg/m]	HDPE	7,60E-03	1,54E-02	3,36E-02	7,52E-02	1,71E-01	3,10E-01	4,37E-01	7,91E-01	1,73E+00	3,35E+00	
	Brass	3,17E-04	5,96E-04	1,05E-03	1,89E-03	3,49E-03	4,98E-03	6,77E-03	9,82E-03	1,60E-02	2,55E-02	
	Steel	2,77E-02	3,48E-02	6,52E-02	9,07E-02	1,49E-01	1,67E-01	2,52E-01	3,55E-01	4,90E-01	9,23E-01	
	Rubber	9,07E-04	1,05E-03	1,71E-03	2,37E-03	2,94E-03	3,45E-03	4,55E-03	9,25E-03	1,19E-02	1,98E-02	
Waste materials on the building site before waste processing, generated by the product's installation [kg/m]	LDPE	3,00E-05	9,40E-05	1,08E-04	1,68E-04	7,33E-03	1,08E-02	1,32E-02	2,25E-02	3,92E-02	4,38E-02	
	Steel	0	0	0	0	2,95E-03	5,13E-03	7,08E-03	1,01E-02	2,14E-02	3,89E-02	
	PET	6,72E-04	8,40E-04	8,57E-04	1,00E-03	4,05E-04	7,02E-04	9,50E-04	1,35E-03	2,83E-03	5,25E-03	
	Wood	0	0	0	0	5,38E-02	9,29E-02	1,26E-01	1,79E-01	3,77E-01	6,90E-01	
Pipe leftovers		2%										
Output materials (specified by type) as result of waste processing at the building site e.g. of collection for recycling,	HDPE	Recycling	7,35E-04	1,26E-03	3,01E-03	6,64E-03	1,43E-02	2,31E-02	3,03E-02	4,72E-02	9,22E-02	1,48E-01
		En. recov.	8,87E-04	1,51E-03	3,63E-03	8,01E-03	1,72E-02	2,78E-02	3,65E-02	5,69E-02	1,11E-01	1,79E-01
		Disposal	1,65E-03	2,81E-03	6,74E-03	1,49E-02	3,20E-02	5,17E-02	6,78E-02	1,06E-01	2,06E-01	3,32E-01
	LDPE	Recycling	8,25E-06	2,59E-05	2,97E-05	4,62E-05	2,02E-03	2,98E-03	3,62E-03	6,19E-03	1,08E-02	1,21E-02

for energy recovery, disposal (specified by route) [kg/m]		En. recov.	7,61E-06	2,39E-05	2,74E-05	4,26E-05	1,86E-03	2,75E-03	3,34E-03	5,71E-03	9,94E-03	1,11E-02	
		Disposal	1,41E-05	4,43E-05	5,09E-05	7,92E-05	3,46E-03	5,11E-03	6,20E-03	1,06E-02	1,85E-02	2,07E-02	
	Steel	Recycling	0	0	0	0	2,80E-03	4,87E-03	6,73E-03	9,61E-03	2,04E-02	3,69E-02	
		En. recov.	0	0	0	0	0	0	0	0	0	0	
		Disposal	0	0	0	0	1,48E-04	2,56E-04	3,54E-04	5,06E-04	1,07E-03	1,94E-03	
	PET	Recycling	2,81E-04	3,51E-04	3,58E-04	4,17E-04	1,69E-04	2,93E-04	3,97E-04	5,64E-04	1,18E-03	2,19E-03	
		En. recov.	1,37E-04	1,71E-04	1,75E-04	2,04E-04	8,25E-05	1,43E-04	1,94E-04	2,75E-04	5,78E-04	1,07E-03	
		Disposal	2,54E-04	3,18E-04	3,24E-04	3,78E-04	1,53E-04	2,66E-04	3,60E-04	5,12E-04	1,07E-03	1,99E-03	
	Wood	Recycling	0	0	0	0	2,60E-02	4,49E-02	6,09E-02	8,64E-02	1,82E-01	3,33E-01	
		En. recov.	0	0	0	0	2,78E-02	4,80E-02	6,51E-02	9,25E-02	1,95E-01	3,57E-01	
		Disposal	0	0	0	0	0	0	0	0	0	0	
	Refilling mass	Disposal	7,37E+02	7,68E+02	8,16E+02	8,85E+02	9,86E+02	1,08E+03	1,14E+03	1,27E+03	1,77E+03	2,56E+03	
	Transport distance for refilling mass to construction site			From Ecoinvent v.3.9 database									
	Energy use for compaction ^a			-									
^a Data about energy consumption are collected as a whole													

C1-C4 – End of life

Collection process specified by type:

	DE20 S5	DE32 S5	DE50 S5	DE75 S5	DE110 S5	DE140 S5	DE160 S5	DE200 S5	DE280 S8	DE355 S5
Collected separately [kg/m]	1,97E-01	3,32E-01	7,70E-01	1,65E+00	3,50E+00	5,62E+00	7,43E+00	1,17E+01	2,27E+01	3,73E+01
Collected with mixed construction waste [kg/m]	0	0	0	0	0	0	0	0	0	0

Recovery system specified by type:

	DE20 S5	DE32 S5	DE50 S5	DE75 S5	DE110 S5	DE140 S5	DE160 S5	DE200 S5	DE280 S8	DE355 S5
For re-use [kg/m]	0	0	0	0	0	0	0	0	0	0
For recycling [kg/m]	6,43E-02	1,00E-01	2,21E-01	4,37E-01	8,98E-01	1,39E+00	1,86E+00	2,89E+00	5,48E+00	9,08E+00
For energy recovery [kg/m]	4,64E-02	8,12E-02	1,92E-01	4,23E-01	9,10E-01	1,48E+00	1,95E+00	3,07E+00	6,03E+00	9,88E+00

Disposal specified by type:

	DE20 S5	DE32 S5	DE50 S5	DE75 S5	DE110 S5	DE140 S5	DE160 S5	DE200 S5	DE280 S8	DE355 S5
Incineration [kg/m]	0	0	0	0	0	0	0	0	0	0
Landfill [kg/m]	8,58E-02	1,51E-01	3,57E-01	7,86E-01	1,69E+00	2,75E+00	3,62E+00	5,70E+00	1,12E+01	1,84E+01

In accordance to the ISO standard, the distance from recycling plant is assumed equal to 500 km, the distance from the incineration plant 200 km and the distance from the landfill 50 km.

9. Other additional environmental information

Emissions to indoor air:

No direct emissions at the building site. Centraletubi S.p.A. confirms that the HDPE waste piping system does not contain any substances mentioned on the REACH SVHC -list.

Emissions to soil and water:

No direct emissions at the building site. Centraletubi S.p.A. confirms that the HDPE waste piping system does not contain any substances mentioned on the REACH SVHC -list.

10. References

Association of Issuing Bodies (AIB), European Residual Mixes - Results of the calculation of Residual Mixes for the calendar year 2022”, rev.1 (01/06/2023).

EC-JRC, EF reference package – Annex C, rev.3.1 (July 2022).

Ecoinvent Database v.3.9.

EN 15804+A2:2019: Sustainability of construction works — Environmental product declarations — Core rules for the product category of construction products.

EPDItaly, Regolamento del programma EPDItaly, rev.6.0 (30/10/2023).

ISO 14025 Environmental labels and declarations - Type III environmental declarations - Principles and procedures.

ISO 14040 Environmental management - Life cycle assessment - Principles and framework.

ISO 14044 Environmental Management – Life Cycle Assessment – Requirements and Guidelines.

Ministero dell'Ambiente e della Sicurezza Energetica, Tabella coefficienti standard nazionali, 2023.

PCR ICMQ-001/15 – Prodotti e servizi per le costruzioni, rev.3 (02/12/2019).

Pré Sustainability, SimaPro database manual – Methods library, rev.4.15 (June 2020).

prEN 16903 - Plastics piping systems - Environmental product declarations - Product Category Rules complementary to EN 15804, for buried plastics piping systems, 2023 (draft).

Remaining service life of plastic pipe after 41 years in service - Ulrich Schulte and Joachim Hessel, 2006.

Schulte U., Hessel J., Remaining service life of plastic pipe after 41 years in service, 2006.

Plastic Pipe Institute, “Handbook of polyethylene pipe” Second Edition.

